



VT-PTZ10

**Ultra-Compact PTZ Camera
with 10x Optical Zoom**



- Built-In 3.8-38mm Lens with 10x Optical / 10x Digital Zoom.
- High Performance 1/4" CCD with 500 TV Lines.
- True Day/Night function with ICR.
- 128 Presets programmed with view direction, zoom, and BLC.
- 4 Patterns record and play back user preference of surveillance path up to 120° sec.
- 8 Scans: 8 speed steps from slow to medium panning with smooth Diagonal Scan.
- 4 Tours: Each tour consists up to 32 Presets, Patterns, and/or Scans.
- 4 Alarm inputs with 1~4 priority / 1 Auxiliary output with programmable NC & NO.
- 8 Privacy Zones: Video off or up to 8 masked blocks
- 64 steps of variable speed from 0.4°/sec to 90°/sec. Max manual speed 190°/sec with Turbo key pressed, Preset speed is 380°/sec.
- Built-in RS-485 receiver driver.
- Built-in power-line surge protection and lightning protection.
- Optional Wall Mount, Indoor/Outdoor pendant housing, and Heater & Blower Kit

VITEK

UNPACKING

Before installing the Dome camera, please make sure that the following items are included in the box:

1. Mini Speed Dome Camera
2. Instruction Manual
3. Mounting Hardware

If any of these materials are missing, please contact the vendor or VITEK customer help desk immediately.

DISCLAIMER

- While every effort has been made to ensure that the information contained in this guide is accurate and complete, no liability can be accepted for any errors or omissions.
- VITEK reserves the right to change the specifications of the hardware and software described herein at any time without prior notice.
- No part of this guide may be reproduced, transmitted, transcribed, stored in a retrieval system, or translated into any language in any form, by any means, without prior written permission of VITEK.
- VITEK makes no warranties for damages resulting from corrupted or lost data due to a mistaken operation or malfunction of the Speed Dome Cameras, peripheral devices, or unapproved/unsupported devices.

WARNING AND CAUTION

WARNING

TO REDUCE THE RISK OF FIRE OR ELECTRIC SHOCK, DO NOT EXPOSE THIS PRODUCT TO RAIN OR MOISTURE. DO NOT INSERT ANY METALLIC OBJECTS THROUGH THE VENTILATION GRILLS OR OTHER OPENINGS ON THE EQUIPMENT.

CAUTION

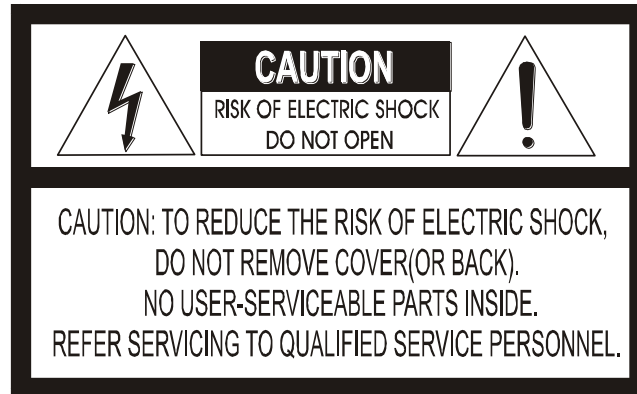

EXPLANATION OF GRAPHICAL SYMBOLS



The lightning flash with arrowhead symbol, within an equilateral triangle, is intended to alert the user to the presence of uninsulated "dangerous voltage" within the product's enclosure that may be of sufficient magnitude to constitute a risk of electric shock to persons.



The exclamation point within an equilateral triangle is intended to alert the user to the presence of important operating and maintenance (servicing) instruction in the literature accompanying the product.

FCC COMPLIANCE STATEMENT

FCC INFORMATION: THIS EQUIPMENT HAS BEEN TESTED AND FOUND TO COMPLY WITH THE LIMITS FOR A CLASS A DIGITAL DEVICE, PURSUANT TO PART 15 OF THE FCC RULES. THESE LIMITS ARE DESIGNED TO PROVIDE REASONABLE PROTECTION AGAINST HARMFUL INTERFERENCE WHEN THE EQUIPMENT IS OPERATED IN A COMMERCIAL ENVIRONMENT. THIS EQUIPMENT GENERATES, USES, AND CAN RADIATE RADIO FREQUENCY ENERGY AND IF NOT INSTALLED AND USED IN ACCORDANCE WITH THE INSTRUCTION MANUAL, MAY CAUSE HARMFUL INTERFERENCE TO RADIO COMMUNICATIONS. OPERATION OF THIS EQUIPMENT IN A RESIDENTIAL AREA IS LIKELY TO CAUSE HARMFUL INTERFERENCE IN WHICH CASE THE USER WILL BE REQUIRED TO CORRECT THE INTERFERENCE AT HIS OWN EXPENSE.

CAUTION: CHANGES OR MODIFICATIONS NOT EXPRESSLY APPROVED BY THE PARTY RESPONSIBLE FOR COMPLIANCE COULD VOID THE USER'S AUTHORITY TO OPERATE THE EQUIPMENT.

THIS CLASS A DIGITAL EQUIPMENT COMPLIES WITH CANADIAN ICES-003.

CET APPAREIL NUMÉRIQUE DE LA CLASSE A EST CONFORME À LA NORME NMB-003 DU CANADA.

CE COMPLIANCE STATEMENT

WARNING

THIS IS A CLASS A PRODUCT. IN A DOMESTIC ENVIRONMENT THIS PRODUCT MAY CAUSE RADIO INTERFERENCE IN WHICH CASE THE USER MAY BE REQUIRED TO TAKE ADEQUATE MEASURES.

IMPORTANT SAFEGUARDS

1. Read these instructions.
 2. Heed all warnings.
 3. Follow all instructions.
 4. Do not use this equipment near water.
 5. Clean only with dry cloth.
 6. Do not block any ventilation openings. Install in accordance with the manufacturer's instructions.
 7. Do not install near any heat sources such as radiators, heat registers, stoves, or other equipment (including amplifiers) that produce heat.
 8. Do not defeat the safety purpose of the polarized or grounding-type plug. A polarized plug has two blades with one wider than the other. A grounding type plug has two blades and a third grounding prong. The wide blade or the third prong is provided for your safety. If the provided plug does not fit into your outlet, consult an electrician for replacement of the obsolete outlet.
 9. Protect the power cord from being walked on or pinched, particularly at plugs, convenience receptacles, and the point where they exit from the equipment.
 10. Only use attachments/accessories specified by the manufacturer.
 11. Unplug this equipment during lightning storms or when unused for long periods of time.
 12. Refer all servicing to qualified service personnel. Servicing is required when the equipment has been damaged in any way, such as power-supply cord or plug is damaged, liquid has been spilled or objects have fallen into the equipment, the equipment has been exposed to rain or moisture, does not operate normally, or has been dropped.
 13. **CAUTION - THESE SERVICING INSTRUCTIONS ARE FOR USE BY QUALIFIED SERVICE PERSONNEL ONLY. TO REDUCE THE RISK OF ELECTRIC SHOCK DO NOT PERFORM ANY SERVICING OTHER THAN THAT CONTAINED IN THE OPERATING INSTRUCTIONS UNLESS YOU ARE QUALIFIED TO DO SO.**
- Use Certified/Listed Class 2 power supply transformer only.

TABLE OF CONTENTS

DISCLAIMER	2
WARNING AND CAUTION	3
FCC COMPLIANCE STATEMENT	4
CE COMPLIANCE STATEMENT	4
IMPORTANT SAFEGUARDS	5
I. INTRODUCTION	8
Features	8
II. INSTALLATION AND CONFIGURATION	9
2.1 Typical System Configuration	9
2.2 Basic Configuration of Speed Dome Camera System	10
2.3 Connecting the Speed Dome directly into the DVR	11
2.4 Connecting the Speed Dome into the Controller via J-box.....	11
2.5 Connecting Both Speed Dome and DVR via J-box	12
2.6 Principle of Termination.....	14
2.7 Dome Camera Address (ID)	16
2.8 Setting Protocols	16
2.9 Connections	17
3.0 Mounting the Dome Camera	18
3.1 Power on and Boot-up Sequence.....	19
III. PROGRAM & OPERATION	20
Dome Camera Selection	20
3.1 FUNCTIONS	21
3.1.1 HOME FUNCTION (MENU =>FUNCTIONS => HOME FUNCTION)	21
3.1.2 PRESET (MENU => FUNCTIONS => PRESET Short Cut: PRST)	22
3.1.3 PATTERN (MENU => FUNCTIONS => PATTERNS or Shortcut: PTRN)	24
3.1.4 SCAN (MENU => FUNCTIONS => SCAN or Shortcut: SCAN)	25
3.1.5 TOUR (or MENU => FUNCTIONS => TOUR, Short Cut: TOUR)	27
3.2 ALARM (MENU => ALARM)	29
3.3 SCREEN	30
3.3.1 LANGUAGE (MENU => SCREEN => LANGUAGE).....	31
3.3.2 PRIVACY ZONE (MENU => SCREEN => PRIVACY ZONE)	31
3.3.3 NORTH DIRECTION (MENU => SCREEN => NORTH DIRECTION)	32
3.3.4 ZONE TITLE (MENU => SCREEN => ZONE TITLE).....	32
3.3.5 CAMERA TITLE (MENU => SCREEN => CAMERA TITLE).....	33
3.3.6 OSD DISPLAY (MENU => SCREEN => OSD DISPLAY)	33
3.4 CAMERA (MENU => CAMERA)	34
3.4.1 FOCUS CONTROL(MENU => CAMERA => FOCUS CONTROL)	34
3.4.2 WB (white balance) (MENU => CAMERA => WB CONTROL)	34
3.4.3 AE CONTROL (MENU => CAMERA => EXPOSURE SETUP)	35
3.4.4 BACK LIGHT COMPENSATION (MENU → CAMERA → Back Light)	36
3.4.5 SHARPENSS CONTROL (MENU => CAMERA =>SHAPENESS)	36
3.4.6 DIGITAL ZOOM (MENU => CAMERA =>DIGITAL ZOOM)	36

3.4.7 NIGHT SHOT MENU (MENU => CAMERA =>NIGHT SHOT).....	36
3.4.8 CAMERA INITIALIZE (MENU => CAMERA =>CAMERA INITIALIZE).....	36
3.5 SETUP (MENU => SETUP)	37
3.5.1 FLIP (MENU => SETUP => FLIP).....	37
3.5.2 SPEED (MENU => SETUP => SPEED).....	37
3.5.3 PRESET FREEZE (MENU => SETUP => PRESET FREEZE).....	37
3.5.4 PANNING RANGE (MENU => SETUP => PANNING RANGE).....	37
3.5.5 TILT LIMIT (MENU => SETUP => TILT LIMIT)	38
3.5.6 CALIBRATION (MENU => SETUP => CALIBRATION).....	38
3.5.7 LINE LOCK CONTROL (MENU = SETUP => LINE LOCK CONTROL).....	39
3.5.8 FACTORY DEFAULT (MENU => SETUP => FACTORY DEFAULT)	39
3.5.9 ERASE DATA (MENU => SETUP => ERASE DATA)	39
3.5.10 SYSTEM INFORMATION (MENU => SETUP => SYSTEM INFORMATION).....	40
Appendix A — Specifications	40
Appendix B — Troubleshooting	43
Glossary.....	44

I. INTRODUCTION

Features

The Speed Dome Camera features a high resolution 1/4" Interline Transfer CCD imager for enhanced lowlight sensitivity. User friendly, on-screen pull-down menus and short-cuts make it easy to setup and program functions.

System information aides trouble shooting by displaying the hardware and software version of the camera's firmware version, baud rate, and protocol.

- Built-in 10X times Optical Power Zoom Camera.
True Night Shot function with ICR Day/Night function.
- 128 **Presets** programmed with view direction, zoom, and BLC.
- 4 **Patterns** record and play back user preference of surveillance path up to 120 sec.
- 8 **Scans**: 8 speed steps from slow to medium panning with smooth **DiagonalScan**.
- 4 **Tours**: Each tour consists up to 32 **Preset, Pattern, and Scan**.
Smooth **DiagonalScan** mode and programmable Individual dwell time camera functions.
(Speed, Dwell time BLC, Focus, IRIS of the preset)
- 4 Alarm inputs with 1~4 priority / 1 Auxiliary outputs programmable NC & NO.
- 8 **Privacy Zones**: Video off or up to 8 masked blocks
- 64 steps of variable speed from 0.4°/sec to 90°/sec.
Max manual speed 190°/sec with **Turbo** key pressed, **Preset** speed is 380°/sec.
- Programmable user preferences of speed (Slow, Medium, and Fast).
- Addressable up to 99 camera IDs (Extendable up to 3999 in special mode).
- Built-in RS-485 receiver driver.
- On-site software upgrade and upload/download of programmed data into the KBD/Dome.
- Built-in power-line surge protection and lightning protection.
- Optional Tinted Bubble, Indoor & Outdoor pendant housing, Heater & Blower.
Flush Mount Kit

II. INSTALLATION AND CONFIGURATION

2.1 Typical System Configuration

Additional Speed Dome joystick controllers and a variety of external switching devices such as multiplexers (MUXes) and Digital Video Recorders (DVRs) may be incorporated to accommodate the needs from a small to a large surveillance/security system. Figure 1 illustrates sample installation.

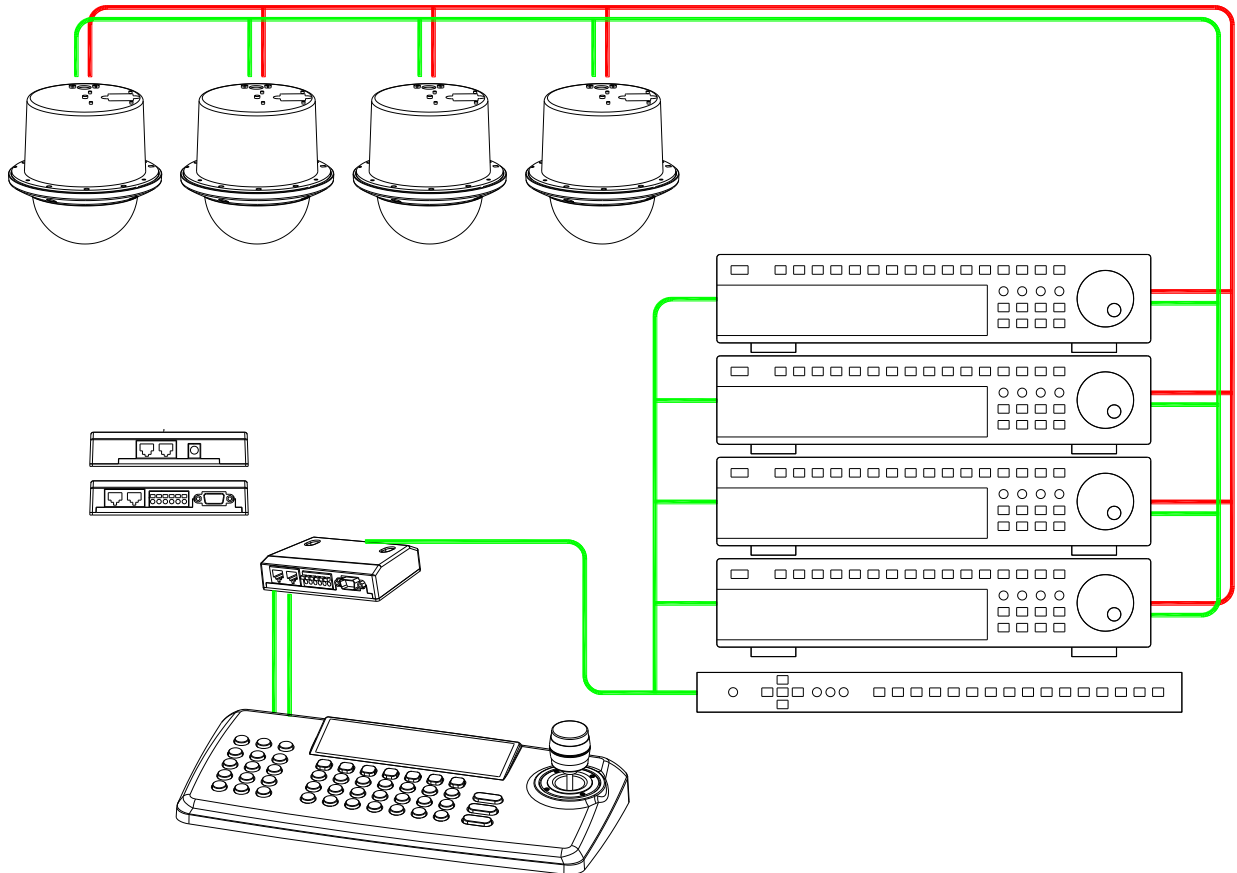

Figure 1 - Typical System Configuration

2.2 Basic Configuration of Speed Dome Camera System

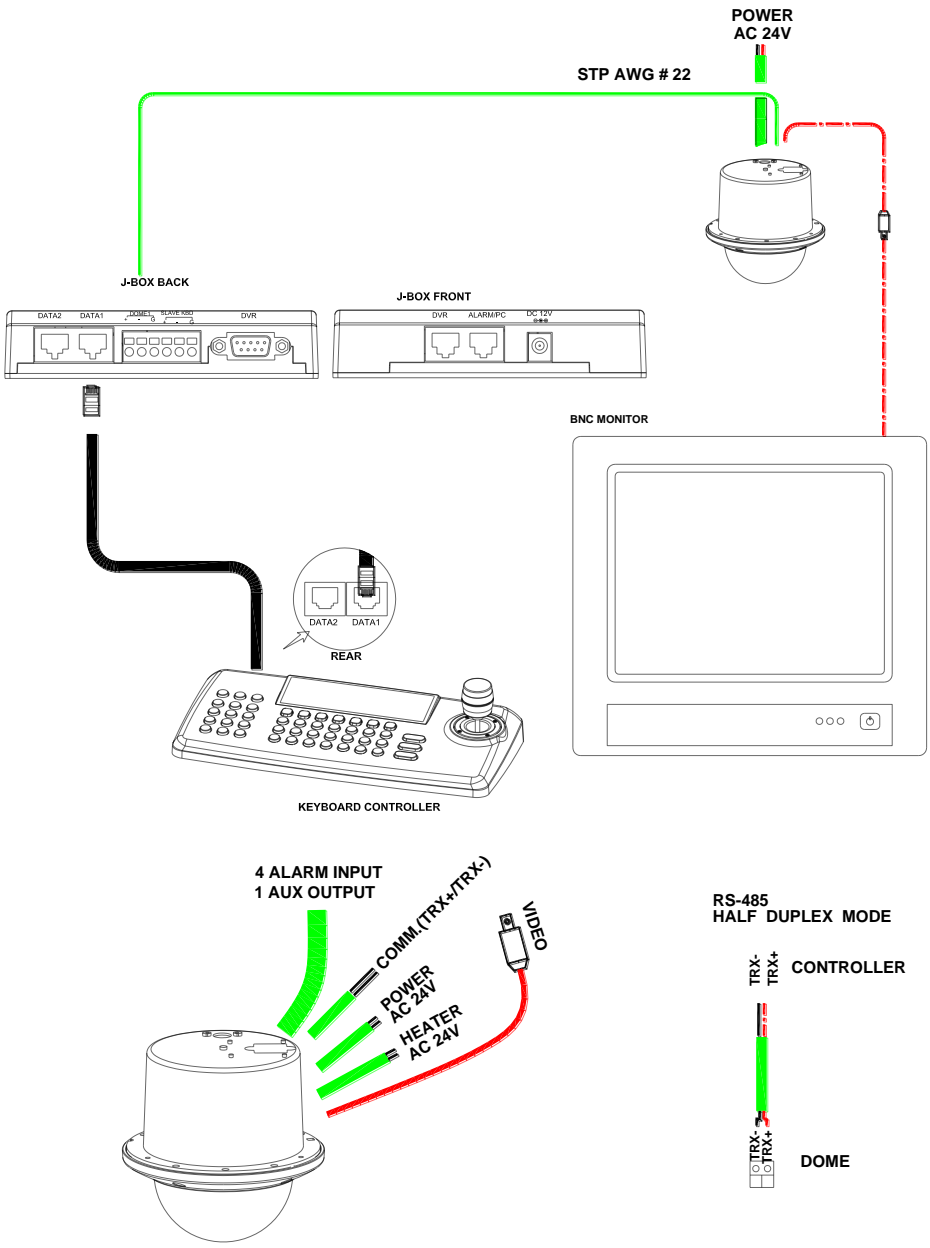

Figure 2 - Basic Installation Diagram

2.3 Connecting the Speed Dome directly into the DVR

- Locate the RS485 + & - conductor wire from the Speed Dome Camera.
- Connect the + & - into the TRX+ & TRX- ports of the DVR. Tx+ & Tx- ports can be found in the rear part of the DVR.

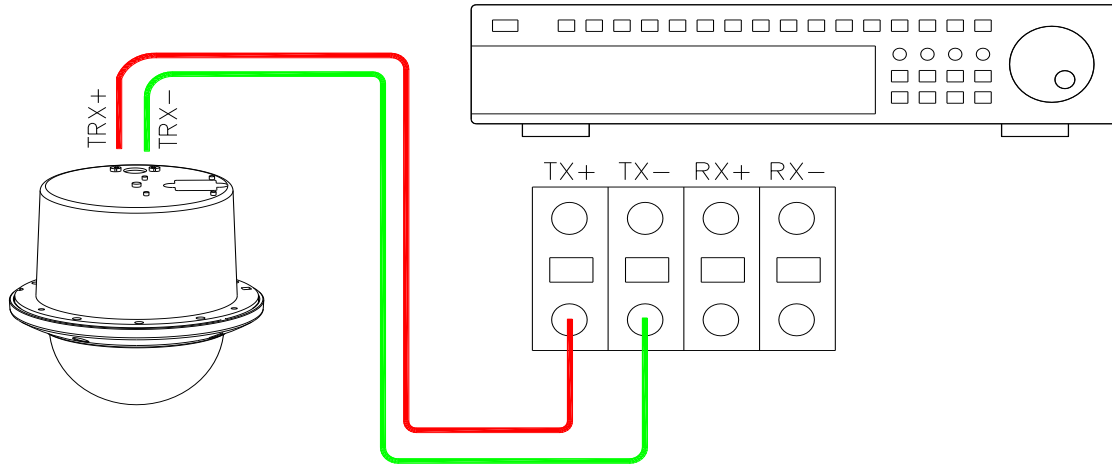

Figure 3 - Camera into DVR

2.4 Connecting the Speed Dome into the Controller via J-box

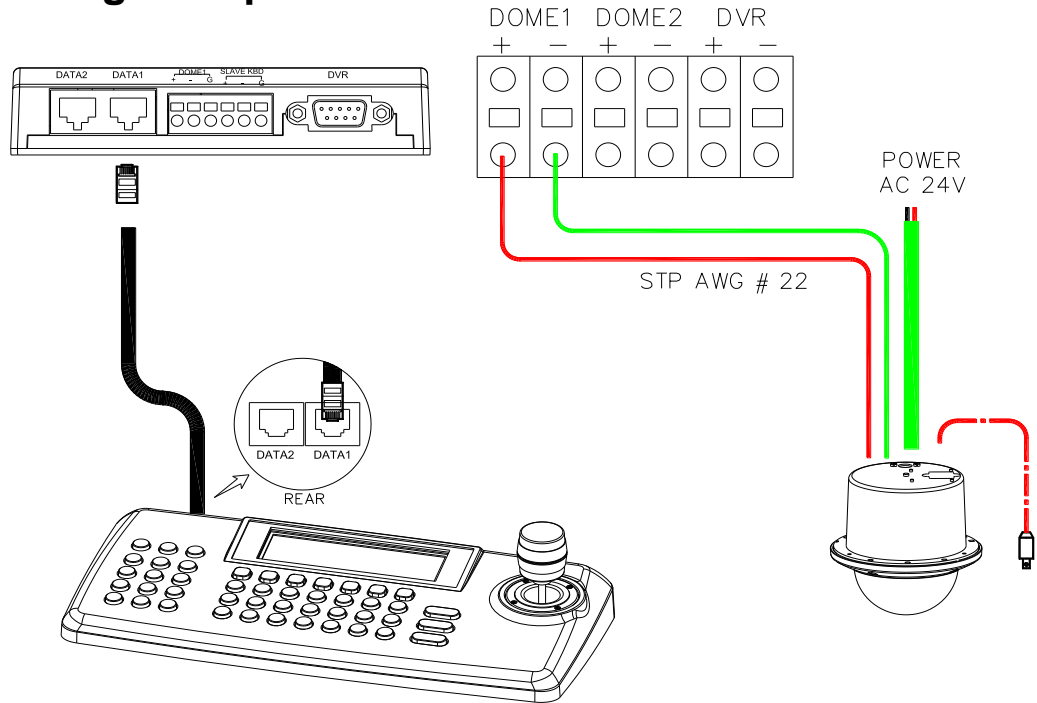

Figure 4 - Camera into Controller

2.5 Connecting Both Speed Dome and DVR via J-box

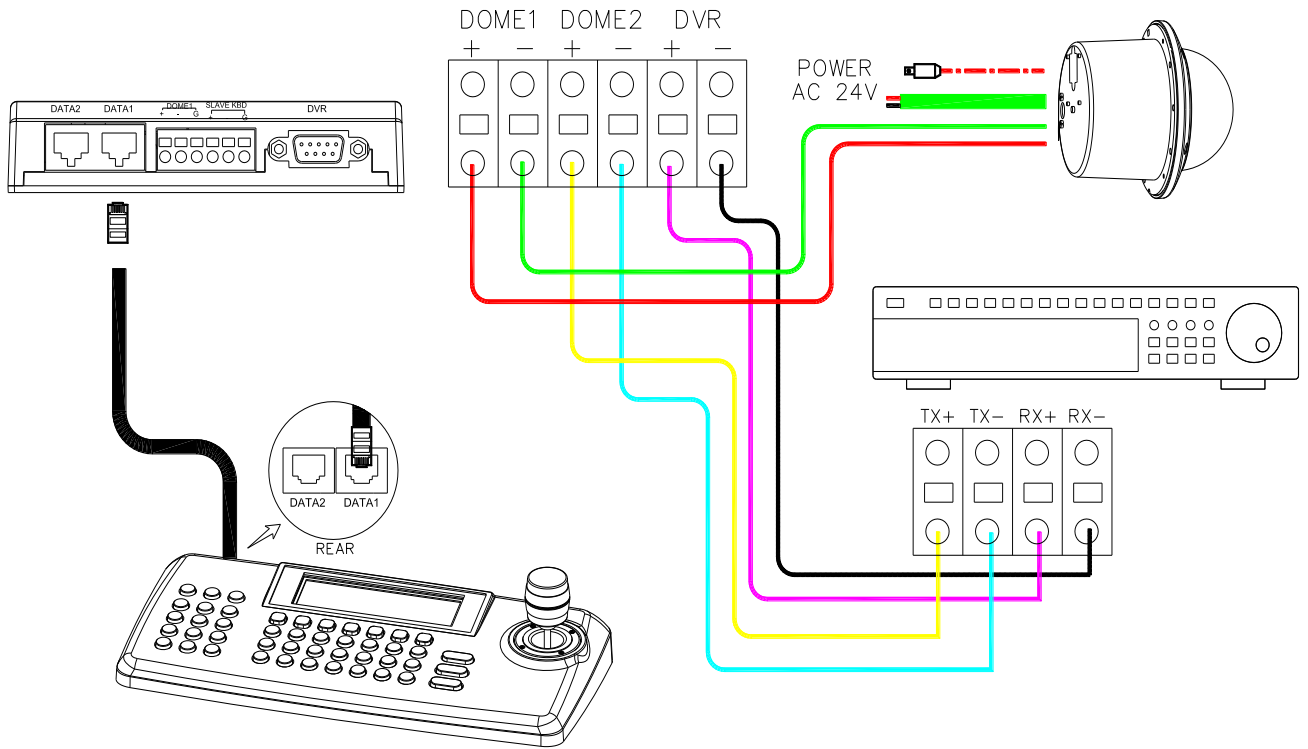

Figure 5 - Connecting Camera & DVR into Controller

The dome camera must be installed by qualified service personnel. Before installing the dome camera system, this instruction manual must be read thoroughly and understood fully. Dome cameras must be set up properly before starting the installation. This involves properly setting configuration switches. Figure 6 shows the location of these switches.

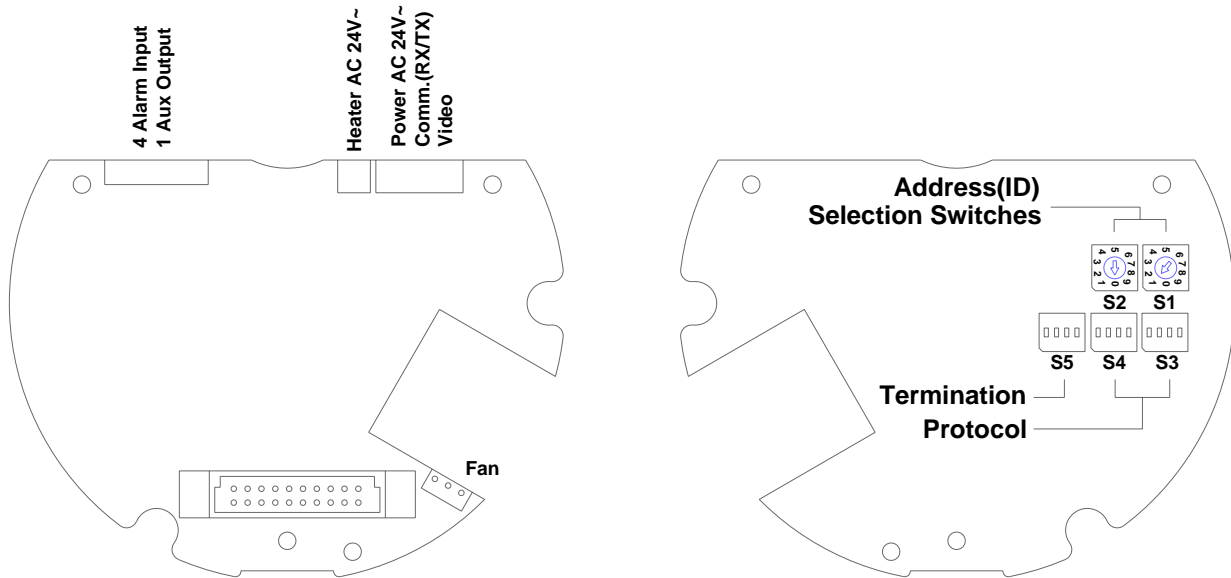

Figure 6 - Layout of Switches

2.6 Principle of Termination

Every device that is connected at the end of the communication data line must be terminated by either the DIP switch setting or an appropriate device such as a termination jumper to prevent potential control signal errors.

See Figure 6 for termination switch settings and Figure 7 for examples of devices requiring termination. Note: Total length of the cable for communication should not exceed 1.2Km or .74 mile.

S5	D1	D2	D3	D4
Terminated	Not Used	X	X	ON
Not terminated		X	X	OFF
Pull Up/Down **		ON	ON	X
Normal **		OFF	OFF	X

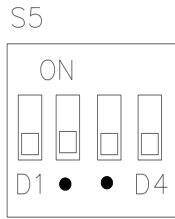

** Unless communication error, put the position 2, 3 of the S5 in OFF state.
Position 2, 3 should be set as a pair. (Both 2, 3 to ON position or OFF position)

Figure 7 - Setting Dome Camera Termination

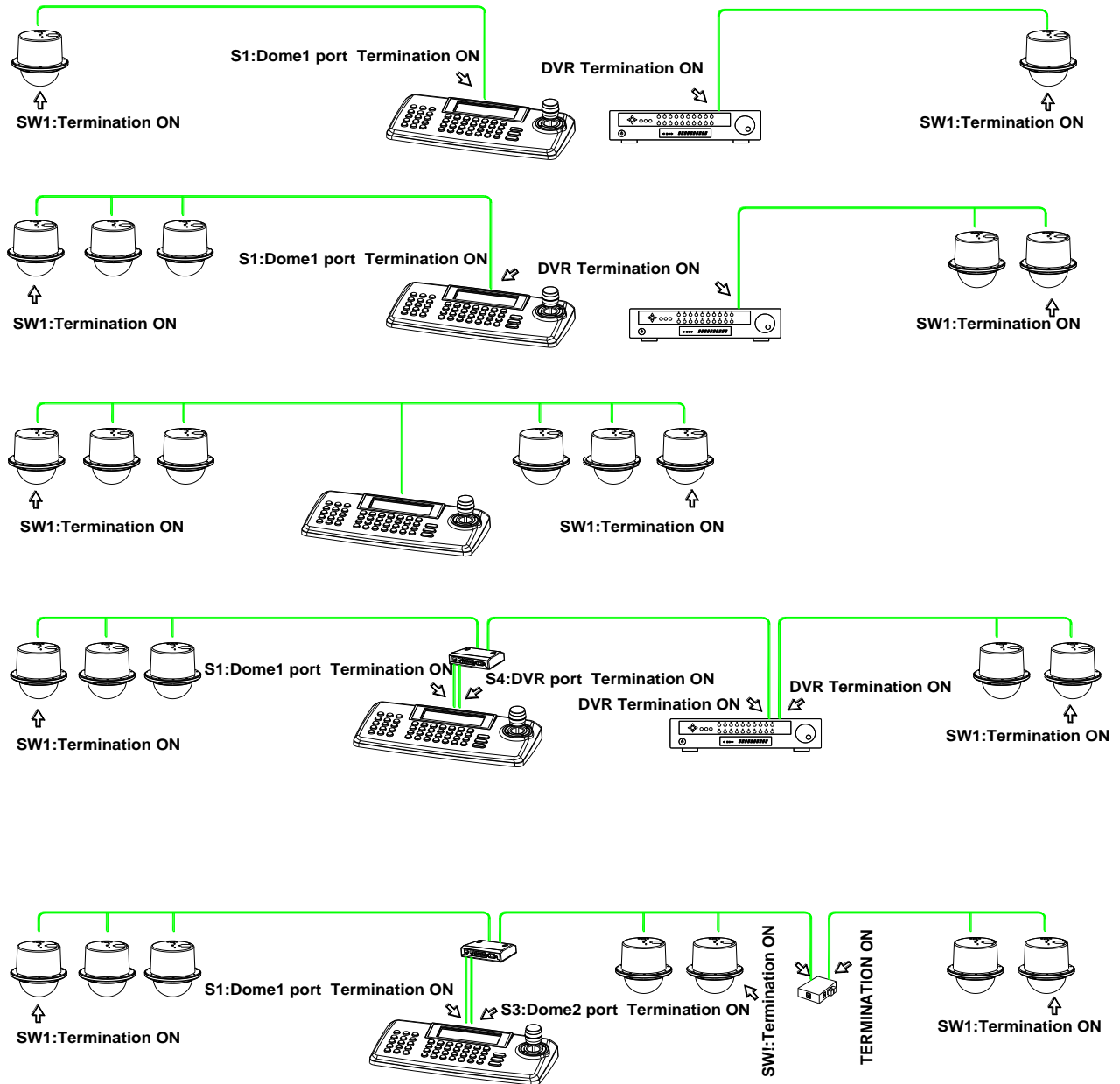

Figure 8 - Termination Diagram

2.7 Dome Camera Address (ID)

Each dome camera must have a unique address (ID). Identical IDs on the same line may damage the control circuit caused by an electrical short. When installing multiple dome cameras or a DVR, it is recommended that the dome camera ID's be identical to the camera port of the DVR.

Cam Port 1 = Dome ID1, Cam Port 2 = Dome ID 2 ... Cam Port 16 = Dome ID 16.

If more than 16 dome cameras are installed using two or more DVRs the following formula is useful to determine the Dome ID: $ID = 16 \times (n-1) + m$ (where n= number of DVR, m=Camera Port)

Refer to Figure 9 for setting the dome camera address (ID) and protocol selection.

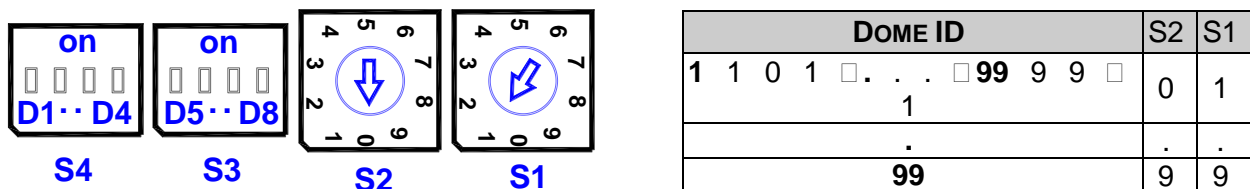

Figure 9 - Setting Dome Camera Address (ID) and Protocol

2.8 Setting Protocols

A **Speed Dome** camera is capable of negotiating with multiple protocols if the communication speed is matched (same baud rate i.e., 9600 bps). See Figure 10 for the appropriate protocol switch settings.

Note: Consult service personnel if a dome camera is installed with a device other than a **recommended Speed Dome Controller**.

Dip S/W		Function	
S4	D1	Protocol	
	D2		
	D3		
	D4		
S3	D5	Baud Rate	
	D6		
	D7		
	D8	Extended ID	

Baud Rate	D5	D6	D7
2400 bps	Off	Off	Off
4800 bps	Off	Off	ON
9600 bps	Off	ON	Off
19200 bps	Off	ON	ON
38400 bps	ON	Off	Off

VIDEO	D8
NTSC	Off
PAL	On

Protocol	D1	D2	D3	D4
AUTO Selection(no parity)	Off	Off	Off	Off
DEFAULT	Off	Off	Off	Off
AUTO selection(even parity)	On	Off	Off	Off
PP	Off	On	Off	Off
EZ	On	On	Off	Off
S2	Off	Off	On	Off
PD	On	Off	On	Off
VC	Off	On	On	Off
SN	On	On	On	Off
DC	Off	Off	Off	On
Reserved	On	Off	Off	On
PS	Off	On	Off	On
Reserved	On	On	Off	On
Reserved	Off	Off	On	On
VL	On	Off	On	On
DI	Off	On	On	On
Reset	On	On	On	On

Figure 10 - Protocol Selection tables

2.9 Connections

• How to Connect RS485

The dome camera has a built-in RS-485 receiver so that it can be controlled remotely by an external control device such as a joystick controller or a DVR.

RS-485: Connect the TXA (Tx+) and TXB (Tx-) of the RS485 control devices (KBD, DVR...) to TRX+, TRX- of the dome camera.

RS-485 does not allow for a star connection layout. A splitter is required if a star connection layout is desired. RS-485 guarantees 1.2 Km of data line routing. A repeater is recommended to extend over 1.2 Km.

• Connecting Video output

Figure 2 – Basic installation diagram

• Connecting Alarms

AL1 to 4 (Alarm In)

Magnetic, PIR or other external sensor devices can be used to signal the dome camera reacting to an event.

See Chapter 3.2 — Program and Operation for configuring alarm input.

GND (Ground)

NOTE: All the connectors marked **GND** are common.

Connect the ground of the Alarm input and/or alarm output to the GND connector.

NO / NC (Normally Opened or Normally Closed dry contact relay output)

The dome camera can activate external devices such as buzzers or lights using dry contact relays. Connect the device to the NO (NC) (Alarm Out) and COM (Common) connectors. See Chapter 3 — Program and Operation for configuring alarm output.

• Connecting the Power

Connect AC 24V 40VA power to the dome camera.

Use certified / Listed Class 2 power supply transformer only.

3.0 Mounting the Dome Camera

Once all DIP switches are set properly and all external connections are made, the dome camera can be mounted.

The **Mini PTZ Dome** camera is designed to mount on a structural body supporting loads up to 3 Kg. See Figure 11.

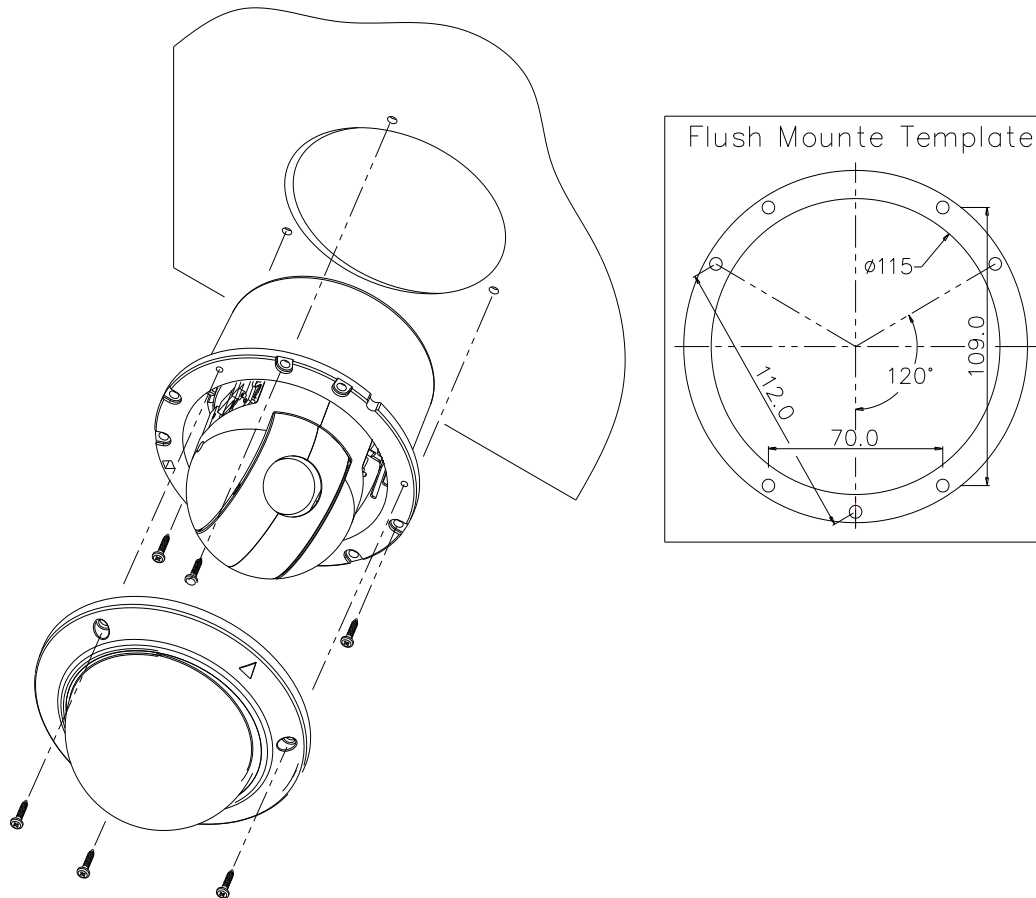

Installation Hint

Using Four ST4X30 screws, affix flush mount base to sturdy surface

Figure 11 - Example of a flush mounted installation

3.1 Power on and Boot-up Sequence

When the power is applied to the dome camera, it will start the boot-up sequence. When boot-up is done, the following information is displayed on the monitor screen.

```

RAM TEST
CHECK NO. : OK!
CHECK AAAA : OK!
CHECK 5555 : OK!
    
```



```

XPRESS DOME Vx.XXX
ID:0001 9600BPS AUTO

CAMERA TYPE XXXX
TILT ORIGIN SET OK
PAN ORIGIN SET OK
INITIAL CAMERA OK
    
```

On Screen Display in normal control mode

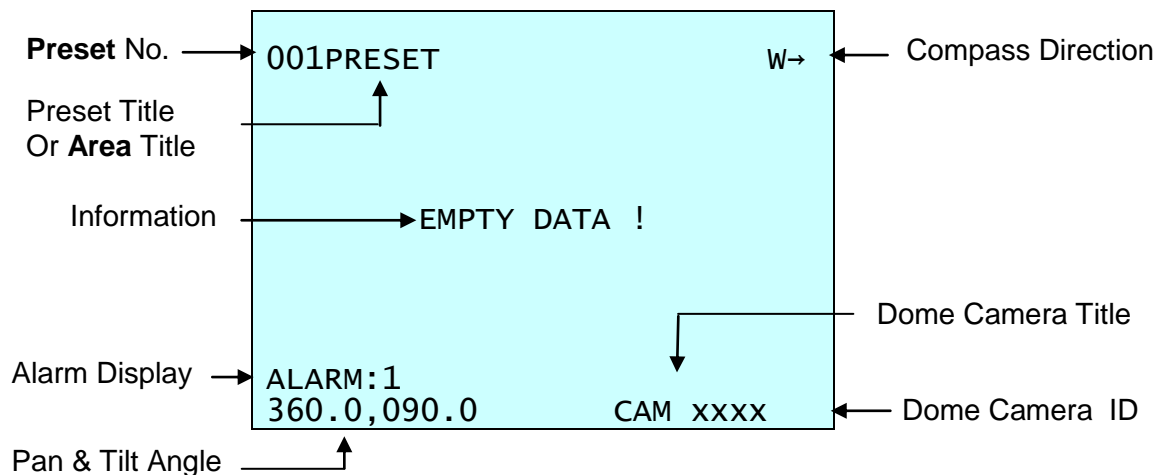







III. PROGRAM & OPERATION

Dome Camera Selection

Prior to starting programming or operating a dome camera, please make sure that both the camera and the joystick controller are communicating. In order for changes to take effect for a camera, particular camera's ID must be selected on the controller.

Example: Pressing **1**, **6** and **CAM** key sequentially will select dome camera 16. The selected dome camera ID will be displayed on the monitor.

Principle of joystick usage in the programming (editing) mode

Button or Joystick movement in menu	Function
 Joystick left or right	Go into the sub-menu items. Execute the command(exit) Change value. Navigate through the menu items.
 Joystick up or down	Navigate through the menu items.
 Joystick down	Finish editing title.
 Zoom handle twist	Change value.(Increase / Decrease) Enter editing title mode.
  SHFT + Joystick	PTZ control mode.
ESC	Escape from the menu without change.
Home or Off button	Delete value or name of the field.

3.1 FUNCTIONS

By pressing the **MENU** button on the keyboard controller, the following On-screen **MAIN MENU** will be shown on the monitor screen.

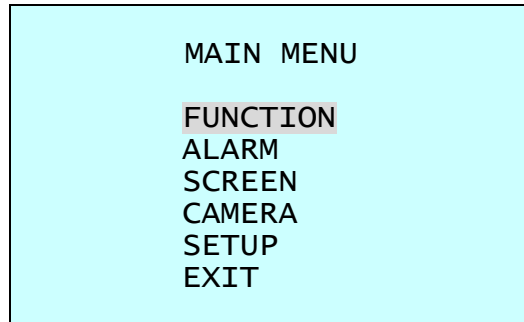

Select the **FUNCTIONS** and then move the joystick to the right to access **FUNCTIONS** menu.

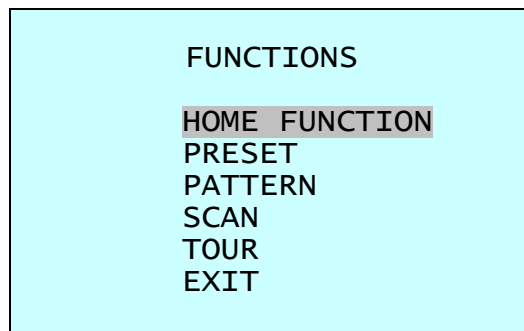

3.1.1 HOME FUNCTION (**MENU** => **FUNCTIONS** => **HOME FUNCTION**)

After **HOME FUNCTION** item has been selected, follow the directions below to set **HOME** function.

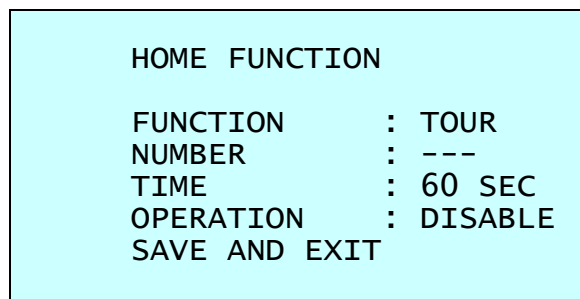

FUNCTION : Tour/ Preset/ Pattern/ Autoscan
 NUMBER : ---
 TIME : 10~240 Seconds
 OPERATION : DISABLE

The **HOME** function applies to the predefined functions such as Preset, Tour, Pattern, or Scan function after the keyboard controller has been idle for a programmed time.

Follow the steps below to program the **Home** function:

1. Select the camera number by pressing **No.** and **CAM**
2. Press **MENU** to display the main menu on the monitor.
3. Moving the **Joystick** to the right on “**FUNCTIONS**”.
4. Enter Home Function menu by moving the **Joystick** to the right.
5. Moving the **Joystick** to the right/ left (or twist CCW/CW) to scroll Tour, Pattern, and Auto Scan and Preset functions.
6. Select Function Number by pulling the **Joystick** down, and twist the **Joystick** to the CCW/CW (or turn right/left). The executable function number will be scrolled. If selected function is not programmed, it won't change. Go to setup function first.
7. Pull the **Joystick** down and twist the **Joystick** to CCW/CW (or twist the joystick to right/left) to set waiting time.
8. Highlight **OPERATION** option by pulling the **Joystick** down. Choose operation status Enable or Disable by moving the **Joystick** to the right or to the left (or twist CCW/CW).

3.1.2 PRESET (**MENU** => **FUNCTIONS** => **PRESET Short Cut:PRST**)

Preset stores pan, tilt, zoom, focus and iris settings. Once programmed, pressing combination of **0** ~ **9** numbers and the **Preset** button on the controller should automatically call up the preset position. Presets may be assigned to alarm actions or as the “home” position for the dome camera.

Highlight **PRESET** and then move the joystick to the right to enter **PRESET** menu.

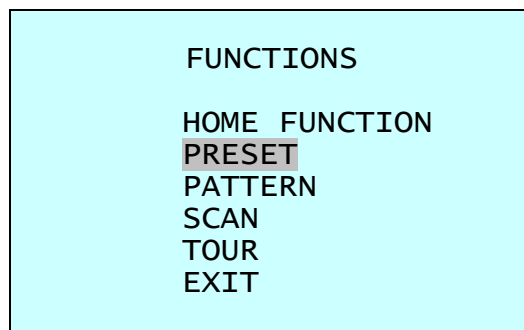

There are 8 pages of preset programming menu. Each page can hold up to 8 presets. Locate the “**PREV** **NEXT**”, preset menu pages can be scrolled by moving the **Joystick** to the Left or Right on the “**PREV** **NEXT**”.

PRESET				01/8
NO.	F	I	B	TITLE
001	A	A	F	XXXXXXXXXXXXXXXXXX
002	M	M	O	-----
003	-	-	-	-----
004	-	-	-	-----
005	-	-	-	-----
006	-	-	-	-----
007	-	-	-	-----
008	-	-	-	-----
PREV NEXT				
SAVE AND EXIT				

F : Focus **I** : IRIS **B** : BLC
X : 16 digit of preset title
- : not defined
█ : Current cursor position

Follow the steps below to program the Preset positions.

1. Select the camera number by pressing **0** ~ **9** and **CAM**.
2. Simply press **PRST** button to enter preset menu. (**MENU** => **FUNCTIONS** => **PRESET**)
3. Select the empty preset location to be programmed by moving the **Joystick** up/down. If selected location is not empty, pressing **PRST** button will display the predefined position.
4. After selecting an empty position, press and hold **SHFT/PGM** then use the **Joystick** to control the direction of the camera and lens. (Or twist the zoom handle or press the zoom button to start PTZ control for view selection.)
5. After aiming the camera (view direction and lens control) to a specific position, release **SHFT/PGM** button (or hit the focus button). The selected location No. field will be filled with "A A F". Move the joystick to the right to select each Focus/ Iris /BLC mode using zoom handle.
6. Move to the title field to edit/enter the name. Rotate the handle CW and CCW or press **Tele** or **Wide** button to scroll through the alphanumeric characters. Moving the handle to right or left to select next or previous digit.
7. To finish entering the title, move the **Joystick** up/down.
8. Locate the cursor on "PREV NEXT" item to select the previous/next page of presets, scroll through the page by moving the **Joystick** to the Left on "PREV NEXT".
9. Repeat the steps 2 through 8 for each additional preset position.
10. Select **Save and Exit** by moving the Joystick to the right. Press **ESC** to exit the Preset menu without saving.

NOTE: Press the **Home** or **OFF** button at programmed position to delete the preset.

SHORTCUT TO PROGRAMMING PRESETS.

Select direction of the camera, zoom and focus to be programmed, then press No. (1~64), and then press **SHFT**, **PRST** subsequently. The current view will be stored to the selected preset number if position is empty. If selected preset number is not empty, "PRESET EXISTING" message will be displayed on the monitor and you will be prompted to overwrite.

Example: **1**, **0** + **PGM** + **PRST** will memorize current view as preset No. **10**. In this case, focus and Iris mode will be memorized as auto and dwell time will be set to 3 sec.

3.1.3 PATTERN (**MENU** => **FUNCTIONS** => **PATTERNS** or Shortcut: **PTRN**)

The Pattern function memorizes and stores movement of the selected dome camera for up to 60 seconds. Pattern can be stored in 60 seconds of total recording space. Stored pattern is played back by pressing **No.**+ **PTRN** buttons subsequently.

PATTERN SETUP		
NO.	TITLE	SEC
01 :	xxxxxxxxxxxxxxxxxxx	000
02 :	xxxxxxxxxxxxxxxxxxx	
03 :	xxxxxxxxxxxxxxxxxxx	
04 :	xxxxxxxxxxxxxxxxxxx	
TOTAL :		000
SAVE AND EXIT		

Follow the steps below to program the Pattern:

1. Press **MENU** key to display the main menu on the monitor.
2. Simply press the **PTRN** key. (or **MENU** => **FUNCTIONS** => **PATTERN**)
3. Select the empty Pattern number to be programmed by moving the **Joystick** Up or Down. If SEC column is not 000, then the selected No. of pattern is already recorded.
4. Press and hold down the **SHFT/PGM** key while controlling the camera direction and zoom with the **Joystick**. The pattern movement will automatically be recorded until releasing the **SHFT/PGM** key. This procedure can be repeated to reprogram the pattern.
(Or twist zoom handle or hit zoom button to start PTZ control for view selection and hit the Focus button to stop.)

5. Scroll down to the Save and Exit option and move the **Joystick** to the right to save and exit.
6. Naming the Pattern can be done by twisting the **Joystick**. Rotate the handle clockwise or counterclockwise to scroll through the alphanumeric characters, move the handle to right or left to select next or previous space.
7. Pressing **ESC** will not save recorded data and will exit to the previous menu. Press the **HOME** or **OFF** button at any programmed position to delete the programmed pattern.

NOTE: If total recording time reaches 120 seconds, it will automatically stop for a moment and start recording again. Previous data will be overwritten.

3.1.4 SCAN (**MENU** => **FUNCTIONS** => **SCAN** or Shortcut: **SCAN**)

The Scan function supports up to 4 programmed sections of angles at 8 programmable speeds.

```

SCAN MENU                                01/8

SCAN 01   : AUTOSCAN01
SPEED    : 1~8/SLW/MID
START    : NONE
END      : NONE
DIRECTION : CCW
SWAP     : OFF
SAVE AND EXIT

```

SPEED (MODE): 1/ 2 / 3/ 4/ 5/ 6/ 7/ 8/ SLOW / MEDIUM
 1: SLOWER ↔ 8 FASTER
 SLW : smooth DiagonalScan in slowest speed
 MID : smooth DiagonalScan in medium speed
 DiagonalScan shows moving path from start point to end point including tilt and zoom** simultaneously.
 **Some models do not change zoom ratio

Follow the steps below to program Scans.

1. Press the **SCAN** key to enter Auto Scan menu directly. (Or **MENU** => **FUNCTIONS** => **SCAN**).
2. Select an Auto Scan number by moving the **Joystick** left or right.
3. Twist the **Joystick** to enter the title by scrolling through the alphanumeric characters and move the handle to the right or left to move to the next space. Press **ENTR** key or move the **Joystick** down to finish title mode.
4. When finish entering the title, select "START ANGLE" with the **Joystick**. Hold down the **SHFT/PGM** key while selecting the start position using the **Joystick**. Current panning position will be displayed. Release **SHFT/PGM** key to complete the selection of the start position. (Or twist zoom handle or hit zoom button to start PTZ control for view selection and hit the Focus button to stop.)
5. Move the **Joystick** downward to select "END ANGLE." Hold down the **SHFT/PGM** key while moving the Joystick to select the end position. The end position angle should be larger than start position. Release the **SHFT/PGM** key to complete the selection of the end position. (Or twist zoom handle or hit zoom button to start PTZ control and hit the Focus button to stop.)
6. Move the **Joystick** downward to select "Tilt & Zoom." Set the zoom and tilt angle by holding down the **SHFT/PGM** key.
7. Moving the **Joystick** downward to select "Speed" and set the speed by twisting the **Joystick** clockwise or counterclockwise or move the **Joystick** left/ right to select the auto scan speed.
8. Select **Save and Exit** by moving the **Joystick** to the right. Press **ESC** to exit the program without saving.

Pressing the **HOME** or **OFF** button to delete stored data, **000** will be displayed immediately.

3.1.5 TOUR (or MENU => FUNCTIONS => TOUR, Short Cut: TOUR)

There are 4 programmable Tours. Each Tour consists of up to 8 Preset positions, Patterns, Scans or other Tours. Using second-level Tours, it can be expanded up to 56 functions in a single Tour. However tours in the second level Tour will be ignored when called by the first level Tour. This can be best illustrated by the following example:

- if** Tour 01 : Preset 02, Preset 03, Tour 02, Tour 03
- Tour 02 : Preset 05, Preset 06, Tour 04, Preset 05
- Tour 03 : Preset 07, Pattern 01
- Tour 04 : Preset 08, Preset 05, Pattern 01

Tour1 executes as follows:

Preset 02 → Preset 03 → Preset 05 → Preset 06 → Preset 05 → Preset 07 → Pattern 01 → ... (Repeat) ---Tour 04 in Tour 02 will be skipped in Tour 01

Tour 02 executes as follows:

Preset 05 → Preset 06 → Preset 08 → Preset 05 → Pattern 01 → Preset 05 ... Repeat (Tour 04 is still valid if called directly from Tour 02.)

```

TOUR 01:xxxxxxxxxxxxxxxxxx          01/04

FUNC NO  S DW TITLE
PRST 064 S 03 -----
PTRN 004 S 03 -----
SCAN 016 S 03 -----
TOUR 004 S 03 -----
---- - - - 03 -----
---- - - - 03 -----
---- - - - 03 -----
---- - - - 03 -----
PREV      NEXT
SAVE AND EXIT
    
```

- xxxxx** : 16 digits of title for tour label
- - -** : blank preset position
- Speed** : F-Normal/ M- Medium D.Scan/ S- Slowest D.Scan
- DWell** : 03-99 Sec
- PRST** : PRESET 1~64
- PTRN** : PATTERN 1
- SCAN** : SCAN 1~4
- TOUR** : TOUR 2~4

Follow the steps below to program the Tours:

1. Press **MENU** => **FUNCTIONS** => **TOUR**, Short Cut: **TOUR MENU** to display the main menu on the monitor. **No.** + **SHFT**+**TOUR** will open directly Tour **No.**
2. Choose an empty location of function by moving the **Joystick** up or down.
3. Stored Preset view can be recalled by pressing **Prst** button, the camera will move to the stored Preset view.
4. To place predefined functions as a Tour, press the function buttons (such as **Tour**, **Ptrn**, or **Scan** ,**Prst**).
Then select function No. by twisting the Zoom handle. (Programmed function No. will be scrolled).
To remove functions from the Tour, press the **HOME** or **Off** button, blank position mark (- - -) will be displayed. You can overwrite the programmed position.
5. Repeat Step 2 through 4 for each desired position. Each title will be displayed on top of the line.
6. Up to 8 Presets, Tours, Patterns Scans can be selected for a Tour. You can expand the Tour sequence by calling other programmed tours. Moving the **Joystick** handle to right or left while the cursor is on the top of the line (TOUR 01) to select another page of the Tour menu. (TOUR 01)
8. You can enter a title for the selected Tour by twisting the **Joystick** while the cursor is on the top of the line (TOUR 01). Rotate the handle clockwise or counterclockwise to scroll through the alphanumeric characters. Move the handle to the right or left to select the next or previous digit.
9. Select Save and Exit by moving the **Joystick** to the right. Press **ESC** to exit the program without saving.

NOTE: All functions should be programmed before being referred to in the tour menu. Otherwise functions won't be selectable by item 4 in the procedure.

3.2 ALARM (MENU => ALARM)

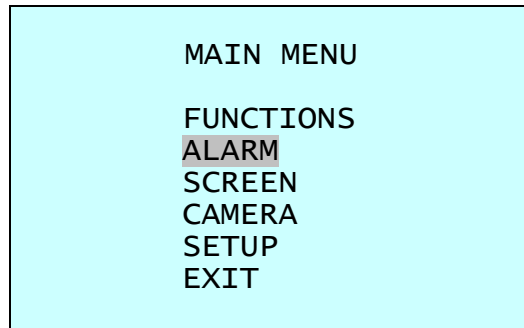

Highlight **ALARM** in the main menu and move the joystick to the right to access **ALARM** setup.

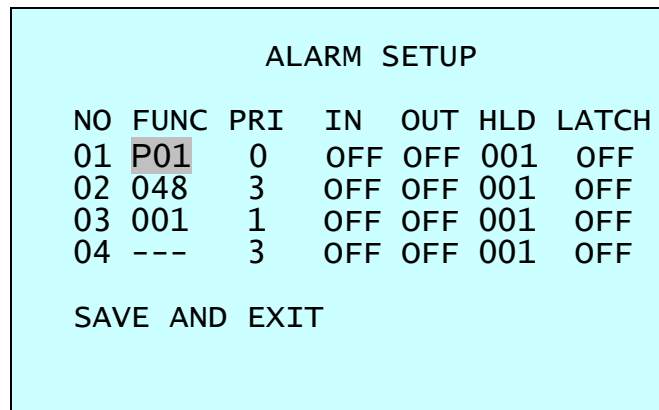

- NO : Alarm input number
 FUNC : Priority 1~4 calls Preset(xxx),
 Priority 0 supports dedicated functions like a Pattern(Pxx), Tour(Txx),
 Scan(Sxx).
 PRI : Lower No. has higher priority, Equal priority alarms will be serviced
 repeatedly.
 IN : NO/NC - normally open /Closed, OFF - ignore
 OUT : R01 - Relay out 1, OFF - No output.
 HLD : Alarm will be held for programmed time (01 to 99 seconds)
 LATCH : ON - Shows all alarms including past alarm, OFF - Shows activated
 alarms only.

There are 5 levels of priority. 0 : Highest priority supports repeated/dedicated functions like a Pattern(Pxx), Tour(Txx), Scan(Sxx). 1~4: Same level of alarm calls presets one after the other.

Ex) Alarm 01 calls Pattern 01, after alarm 01 is released alarm 02, 03 will call **preset 48** and **preset 01**

1. Press Menu to display the main menu on the monitor. Select the Alarm option by moving the **Joystick** up/down and then move to the right to enter the detail menu.
2. Select the alarm input number by moving the **Joystick** up or down and select the column to setup. Selected position will be highlighted.
3. Select the Preset, Status of Input (NC/NO/OFF), and Output (OUT1~2/OFF) by moving the Joystick to the right or to the left.
4. To increase or decrease the preset number or to change the status or output number, twist the **Joystick** clockwise or counterclockwise. In case of preset, programmed preset number will be scrolled.
5. Locate the cursor on **Save and exit** and moving the **Joystick** to the Save and exit.
Press **ESC** to exit the program without saving.

3.3 SCREEN

By pressing the **MENU** button on the keyboard controller, the following On-screen **MAIN MENU** will be shown on the monitor screen.

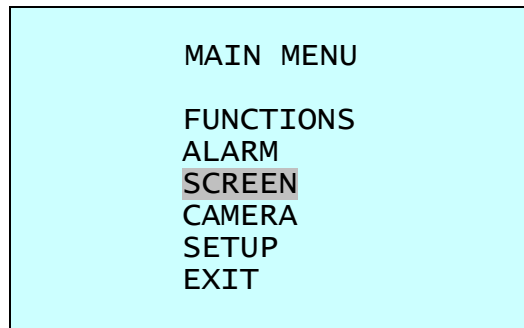

Highlight **SCREEN** and then move the joystick to the right to enter **SCREEN** menu.

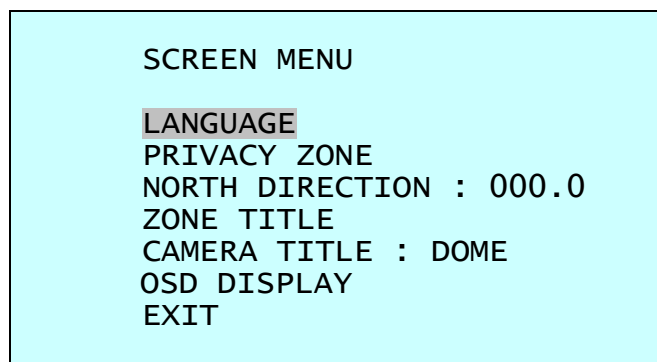

3.3.1 LANGUAGE (**MENU** => SCREEN => LANGUAGE)

Moving the joystick handle to the right to select **LANGUAGE** options. Preferred language will be scrolled by moving the joystick to the right on **LANGUAGE ENGLISH**.

3.3.2 PRIVACY ZONE (**MENU** => SCREEN => PRIVACY ZONE)

Highlight **PRIVACY ZONE** and then move the joystick to the right to enter the menu.

```

SCREEN MENU

LANGUAGE
PRIVACY ZONE
NORTH DIRECTION : 000.0
ZONE TITLE
CAMERA TITLE : DOME
OSD DISPLAY
EXIT
  
```

This function disables the viewing of restricted areas for privacy reasons. It offers masking up to 8 unwanted views in a camera.

```

PRIVACY ZONE SETUP

NO      TITLE                MASK
01 xxxxxxxxxxxxxxxxxxxx  ON BLOCK
02 xxxxxxxxxxxxxxxxxxxx  OFF V.OFF
03                                     NONE ----
04                                     NONE ----
05                                     NONE ----
06                                     NONE ----
06                                     NONE ----
08                                     NONE ----
SAVE AND EXIT
  
```

1. Select the Privacy Zone option by moving **Joystick** Up or Down and move the joystick to right to enter the detail menu.
2. Select the privacy zone number by moving the Joystick up or down.
3. To enter the zone name, rotate the handle clockwise or counterclockwise. Select alphanumeric characters by rotating the handle. Move to the next character position by moving the Joystick to the right. To finish entering the title, move the **Joystick** down or press the **ENTR** key.

4. To adjust the “marked” (privacy) area, press and hold down the **SHFT/PGM** key and then use the **Joystick** (direction and zoom) until getting desired view. Release the key, the right column will be set to ON. (Or twist the zoom handle or hit the zoom button to start PTZ control for view selection and hit the Focus button to exit from control mode.)
5. Use the Home key to delete the marked zone, or move the **Joystick** to the right or left to turn the stored zone On or Off.
6. Select the Save and Exit option by moving the **Joystick** up or down. Save and exit the program by moving the **Joystick** to the right. Press **ESC** to exit the program without saving.

Press the **HOME** or **Off** button to delete programmed privacy zone.

3.3.3 NORTH DIRECTION (**MENU** => **SCREEN** => **NORTH DIRECTION**)

Move the joystick handle to the right to select **NORTH DIRECTION** options.

1. Select DISPLAY option to turn on or off the function.
2. Move to **POSITION** item to set north direction, press and down the **SHFT/PGM** key and then use the **Joystick** (direction and zoom) until to get the desired direction. Release the key then current pan angle will be displayed on position item. (Or twist the zoom handle or hit the zoom button to start PTZ control for view selection and hit the Focus button to exit from control mode.)

3.3.4 ZONE TITLE (**MENU** => **SCREEN** => **ZONE TITLE**)

Enter a specific name in sectioned angle between START and END.

ZONE TITLE			
			01/04
NO	TITLE	START	END
01	WINDOW	123.4	345.6
02		-----	-----
03		-----	-----
04		-----	-----
05		-----	-----
06		-----	-----
PREV NEXT			
SAVE AND EXIT			

1. Press **MENU** => **SCREEN** => **ZONE TITLE** to display zone title menu on the monitor.

2. Select the zone number by moving the **Joystick** up or down. Select Start, End or number column to be set by moving the handle to the right or left. The selected column will be highlighted.
3. Twist the joystick handle on the No. column to enter zone title. Select alphanumeric characters by rotating the handle. Move to the next character by moving the **Joystick** to the right. To finish entering the title, move the **Joystick** down.
4. To adjust panning limit, press the **SHFT/PGM** key and hold down. Then use the **Joystick** to go the desired direction. The end limit must be in an increasing direction. (Start < End). (Or twist the zoom handle or hit the zoom button to start PTZ control for view selection and hit the Focus button to exit from control mode.)
5. **PREV NEXT** : go to previous page or next page of the menu
6. Save and exit the program by moving the **Joystick** to the right. Press ESC to exit the program without saving.

3.3.5 CAMERA TITLE (**MENU** => **SCREEN** => **CAMERA TITLE**)

Move the joystick handle to the right to select **CAMERA TITLE** options.

This function allows the users to set the title of camera as well as the usage of on screen display of the title.

Twist the joystick handle on the **CAMERA TITLE : DOME** to enter camera title. Select alphanumeric characters by rotating the handle. Move to the next character by moving the **Joystick** to the right. To finish entering the title, move the **Joystick** down.

3.3.6 OSD DISPLAY (**MENU** => **SCREEN** => **OSD DISPLAY**)

OSD DISPLAY	
FUNCTION TITLE	: ON
CAMERA TITLE	: ON
ZONE TITLE	: ON
NORTH DIRECTION	: ON
DOM E POSITION	: ON
DOM E ID.	: ON
ZOOM MAGNIFICATION	: ON
FAN STOP WARNING	: ON
EXIT MENU	

FUNCTION TITLE : turn on or off the preset, pattern, scan, tour title display.

CAMERA TITLE : turn on or off the camera title display.

ZONE TITLE : turn on or off the zone title display.

NORTH DIRECTION : turn on or off the azimuth direction display.

DOME POSITION : turn on or off the coordinates display.

DOME ID : turn on or off the dome ID display.

ZOOM MAGNIFICATION : turn on or off the current zoom magnification level display.

3.4 CAMERA (**MENU** => CAMERA)

NOTE: The menu features will vary depending on the camera module.

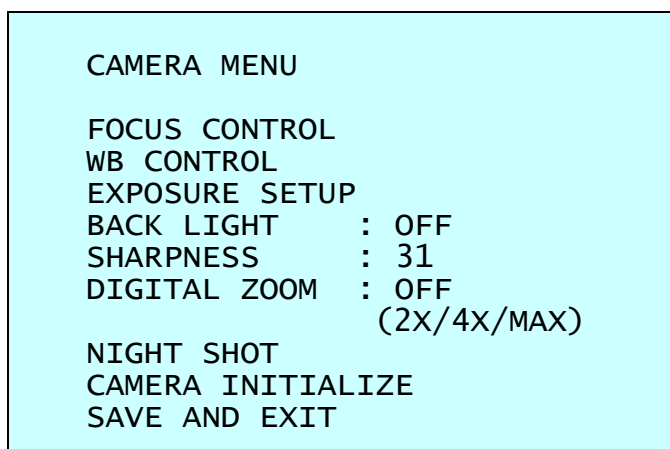

3.4.1 FOCUS CONTROL(**MENU** => CAMERA => FOCUS CONTROL)

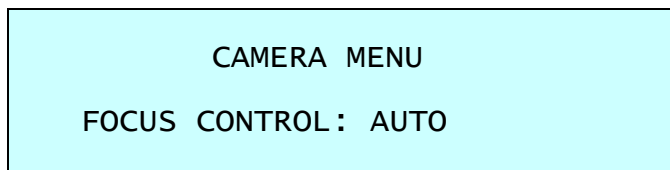

MODE : AUTO / ONE-PUSH / MANUAL

AUTO : Focus is automatically adjusted with moving zoom.

ONE-PUSH : Focus is automatically adjusted just once, after zoom position is changed.

MANUAL : Focus can be manually adjusted, independent of moving zoom.

CAUTION: Please avoid continuous, 24-hour use of the auto focus under heavy movement condition. This will shorten the lifespan of the lens.

3.4.2 WB (white balance) (**MENU** => CAMERA => WB CONTROL)

WB SETUP	
MODE	: OUTDOOR
R GAIN	: 30
B GAIN	: 40
EXIT	

MODE MANUAL / OUTDOOR / INDOOR / AWC

R GAIN 0 ~ 100

B GAIN 0 ~ 100

Use the AWC mode for normal use.

RGAIN / BGAIN modes are controllable only in MANUAL Mode

Moving the **Joystick** to the right or left to change.

NOTE: "ONE PUSH" means that when rotating the **Joystick** handle for a moment the lens moves to adjust the focus for the subject. The focus lens then holds that position until the **Joystick** handle rotation.

3.4.3 AE CONTROL (**MENU** => CAMERA => EXPOSURE SETUP)

EXPOSURE SETUP	
BRIGHT	: 025
IRIS	: AUTO
IRIS VALUE	: 080
SHUTTER	: ESC(NOR)
SHUTTER SPEED	: 1/60
AGC	: NORMAL
DNR(SSNR)	: OFF
DSS	: AUTO
EXIT MENU	

BRIGHT : 0~100

IRIS : AUTO / MANUAL

IRIS VALUE : 0 ~ 100

SHUTTER : ESC(NOR) / MANUAL / A.FLK

SHUTTER SPEED : 2 ~ 1/120,000 sec

AGC : NORMAL / HIGH / OFF

DNR(SSNR) : OFF / LOW / MID. / HIGH

On screen noise reduction

DSS : AUTO / OFF

This feature ensures clear images at night or under low lighting conditions.

3.4.4 BACK LIGHT COMPENSATION (**MENU** → CAMERA → Back Light)

Objects in front of bright backgrounds will be clearer with BLC ON.
LOW / MID. / HIGH / OFF

3.4.5 SHARPNESS CONTROL (**MENU** => CAMERA =>SHARPNESS)

Higher the value, outlines of the image will be enhanced (0~31)

3.4.6 DIGITAL ZOOM (**MENU** => CAMERA =>DIGITAL ZOOM)

OFF - Optical zoom only
2x,4x, Max. - Digitally magnifies up to 2x, 4x 10x respectively.

3.4.7 NIGHT SHOT MENU (**MENU** => CAMERA =>NIGHT SHOT)

The NIGHT SHOT option removes the IR Cut filter of the camera and makes the camera sensitive to near infrared.

If NIGHT SHOT mode of the selected camera is set to Manual, **10+ ON** will enable the NIGHT SHOT mode, **10+ OFF** will turn off the NIGHT SHOT mode.

NIGHT SHOT SETUP	
MODE	: AUTO
LOCAL CONTROL	: COLOR
EXIT	

MODE : MANUAL / AUTO

AUTO – Camera automatically goes into B&W mode at low light.

MANUAL - Manually controls the Night Shot mode in LOCAL CONTROL option. On/Off Night Shot mode remotely by pressing **10+ ON**/**10+ OFF**.

3.4.8 CAMERA INITIALIZE (**MENU** => CAMERA =>CAMERA INITIALIZE)

Returns all changed camera values to factory default.

```
CAMERA INITIALIZE
```

```
ARE YOU SURE : (Y/N)  
YES : ENTER OR MENUKEY  
NO : ESC KEY
```

3.5 SETUP (**MENU** => **SETUP**)

```
CONFIGURATION MENU
```

```
FLIP FUNTION : ON  
P/T SPEED : FAST  
PRESET FREEZE : OFF  
PANNING RANGE  
TILT LIMIT : ON  
CALIBRATION  
LINE LOCK CONTROL  
FACTORY DEFAULT  
ERASE DATA  
SYSTEM INFORMATION  
SAVE AND EXIT
```

3.5.1 FLIP (**MENU** => **SETUP** => **FLIP**)

When the Speed Dome camera is mounted on a ceiling, it can track a moving target in a path directly below the camera:

ON - When the camera reaches the moving object directly above the floor, the dome camera tracks the object smoothly with a digitally corrected image.

OFF – The dome camera does not perform a flip.

3.5.2 SPEED (**MENU** => **SETUP** => **SPEED**)

User can select preferable speed curves of manual control.(FAST / MEDIUM / SLOW)

3.5.3 PRESET FREEZE (**MENU** => **SETUP** => **PRESET FREEZE**)

This option is used to set the pause previous image until the preset action is complete.

3.5.4 PANNING RANGE (**MENU** => **SETUP** => **PANNING RANGE**)

```
PAN RANGE SETUP
```

```
RIGHT LIMITE   : 000.0
LEFT LIMIT     : 007.2
ENABLE        : ON / OFF
SWAP RIGHT LEFT
SAVE AND EXIT
```

When the dome camera is installed near a wall or on a corner, panning range can be limited by user.

3.5.5 TILT LIMIT (MENU => SETUP => TILT LIMIT)

Turn Tilt Limit OFF to allow the camera to have full range of tilting ability from 0 to 180 degree.

Turn Tilt Limit On to limit the tilting range by up to +10 degree on both ends.

During zoom-out operation the tilting range is increased slightly by additional +10 degree.

3.5.6 CALIBRATION (MENU => SETUP => CALIBRATION)

```
CALIBRATION
```

```
RESET ORIGIN
ORIGIN OFFSET : 000.0 , 000.0
ACTIVE OFFSET : DISABLE/ENABLE
AUTO CALIBRATION : OFF
SAVE AND EXIT
```

RESET ORIGIN : Calibrate the ORIGIN point.
 OFFSET ORIGIN : Adjust the small amount of position error from re-installation.
 ACTIVE OFFSET : Apply the adjustment above or not
 AUTO CALIBRATION : ON – When position error detected, recover automatically.
 OFF – Disregard the position error.

3.5.7 LINE LOCK CONTROL (MENU = SETUP => LINE LOCK CONTROL)

```

LINE LOCK SETUP

MODE      :          INTERNAL
PHASE    :          (0~359)
EXIT

```

MODE	INTERNAL / EXTERNAL	Adjusts phase of picture with other
PHASE	0~359	cameras in EXTERNAL mode.
EXIT (ESC TO EXIT)		

3.5.8 FACTORY DEFAULT (MENU => SETUP => FACTORY DEFAULT)

```

FACTORY DEFAULT

ARE YOU SURE : (Y/N)
YES  : ENTER OR MENU KEY
NO   : ESC KEY

```

Programmed data go back to initial state as ex-factory

3.5.9 ERASE DATA (MENU => SETUP => ERASE DATA)

```

ERASE PROGRAMMED DATA

ARE YOU SURE : (Y/N)
YES  : ENTER OR MENU KEY
NO   : ESC KEY

```

Erase programmed data in the EEPROM of the selected dome camera. Press **MENU** or **ENTER** button to erase data, **ESC** key to exit without erasing. Origin offset value is not affected.

CAUTION: Unless you download the data into a safe place, all the data in the selected dome camera will be lost. (Refer to Download/ Upload data function in the Keyboard Configuration utility)

3.5.10 SYSTEM INFORMATION (MENU => SETUP => SYSTEM INFORMATION)

SYSTEM INFORMATION	
CAMERA TYPE	: XXXXXXXX
H/W VERSION	: V1.00
ROM VERSION	: V1.00
PROTOCOL	: EZ
BUADRATE	: 9600BPS
EXIT MENU	

This screen shows information of the dome camera for service or trouble shooting

APPENDIX A — SPECIFICATIONS

Lens

Camera	
Image Sensor	1/4" Interline Transfer CCD(Sony)
Picture elements	NTSC : 768x494 Approx. 380K pixels PAL : 752x582 Approx. 440K pixels
Horizontal Resolution	500 TV Lines
Lens	10x optical zoom with auto focus 10x digital zoom F1.8 to F3.0, f=3.8mm to 38mm
View angle	Approx. 51.2° (WIDE end) to 5.58° (TELE end)
Minimum Illumination	0.7 lux(F1.8,normal shutter speed) 0.02 lux (F1.8, IR Cut Filter Removed) 0.005 lux (F1.8, DSS Auto with IR Cut Filter Removed)
S/N ratio	more than 50dB

Controller specifications

General	
Certification	CE EMC, FCC CLASS A
Electrical	
Input Voltage	18 to 30 VAC; 24 VAC nominal, built-in power-line surge
Power Requirement	24 VAC/VDC 700mA
Power Consumption	Maximum 15W / 30W(Heater Use)

Alarm Output	1 Normal relays 24 VDC/1A Max (selectable NC/NO)
Alarm Input	4 Normal dry contact (selectable NC/NO)
Control	RS-485 baud rate:2400~38400bps (default:9600bps)
Access Time	0.75 second maximum preset recall time
ID (Camera Address)	Physical 99, Logical 3999
Mechanical	
Dimension	See Figure 10
Weight	Approx 1.2 kg
Pan Angle	360° continuous rotation
Speed	0.4° to 90°/sec. (proportional to zoom)
	190°/sec. maximum (with Turbo key pressed)
	Preset Speed : 380°/sec
Repeatability	0.2°
Flip	Rotate 180° at bottom of tilt
Autoscan	4 auto scan include vector scan/1 Auto Pan
Preset Position	128 positions with camera status (16-character title)
Tour	4 tours
Pattern	4 patterns, 120 second
On-Screen Display	Displays camera ID and area name on screen
Environment	
Operating temperature	0°C to 50°C (32°F to 122°F) -30°C to 50°C (-22°F to 122°F)
Operating humidity	0 to 90%RH (non-condensing)
Storage temperature	-20°C to 60°C (4°F to 140°F)

Specifications are subject to change without notice.

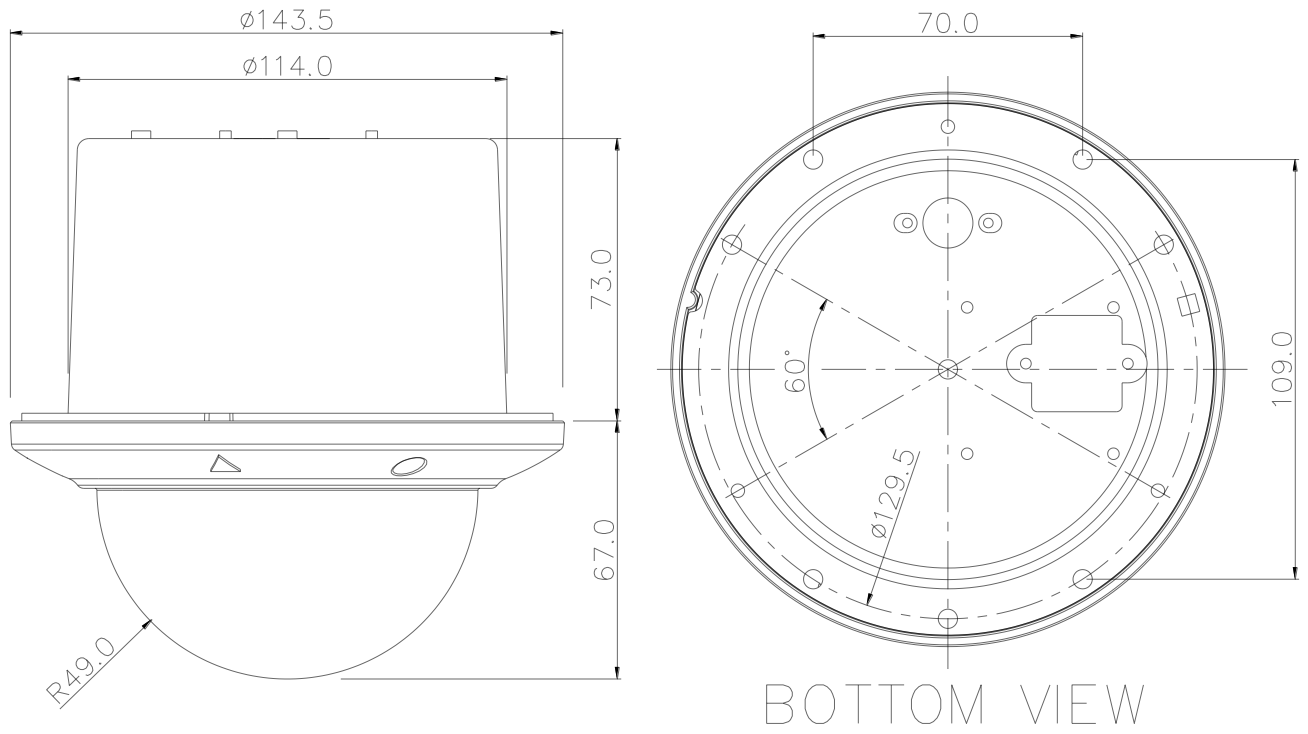

Figure 10-Dimension

Appendix B — Troubleshooting

If problems occur, verify the installation of the camera with the instructions in this manual. Isolate the problem from the equipments in the system and refer to the equipment manual for further information.

Problem	Solution
No video.	Verify that power is connected to all components in the system. Verify that the power switches are ON. Check that the BNC connectors are securely connected. (see Figure 4).
Poor video quality.	Check the voltage level of the dome camera. Check the power supply voltage (nominal 24VAC)
Dome cameras lose their positions.	Reset the cameras using the Dome configuration menus. Check if there is unusual sound. Check the voltage level of the dome camera.
Camera number does not match the multiplexer number.	Check the camera ID and connect the BNC cable into the proper input of the multiplexer.
Picture is torn when switching	Adjust phase of Line Lock.

Glossary

ALARM ACTIONS

The assigned responses of the dome camera when there is input status change. The dome may call Presets for each of the eight inputs. The dome reports the alarm states to the Keyboard controller for processing.

AREA TITLE

It is the name of the horizontal sector from a certain start point to end point of the selected dome. Up to 24 areas can be programmed for the dome.

AUTOMATIC GAIN CONTROL (AGC)

Allows for the amplification of the video signal in scenes with minimal ambient light. Many low-light scenes result in picture noise. As gain is increased, the picture noise is also amplified. When AGC is enabled, the value of the gain setting is based on feedback from the camera. When AGC is disabled, the camera uses the value set for the manual gain setting. The trade-off between picture level and noise may be adjusted when AGC is disabled.

DIAGONALSCAN

Move from start point to end point including tilt and zoom simultaneously and linearly.

DIGITAL SLOW SHUTTER (DSS)

DSS enhances video quality in extreme low-light situations. When the Low Shutter setting is enabled, low-light information is collected over multiple fields based on the Shutter Limit setting. As a result, video may appear blurred or choppy in extreme low-light situations. This setting does not effect camera operation in normal lighting situations. See also Automatic Gain Control (AGC).

FLIP/ DIGITAL FLIP

It allows the dome to turn 180 degrees when the camera tilts to its lower limit. When the dome flips (rotates), the camera starts moving upward as long as the tilt control is kept in the down position. Once the control is released, the tilt control returns to its normal operational mode. The flip feature is useful when you need to track someone who walks directly beneath the dome and continues on the other side.

HOME POSITION

The default position to which the dome camera returns after an assigned period of inactivity passes. The default position may be a Preset, Tour, Pattern, or No Action.

INPUT ALARM

A connection point on the dome camera that enables the system to monitor Input Devices. There are four inputs available for the dome camera.

INPUT DEVICES

External devices that provide information about the condition of system components that connect to the inputs on the dome camera. Typical input devices include door contacts, motion detectors and smoke detectors.

IR MODE

A feature of the camera that permits manual or automatic switching between color and IR (black-and-white) operation. When IR mode is active, clearer images may be obtained under low-light conditions.

LINE LOCK

When line lock is enabled, it prevents vertical video rolling when switching multiple cameras to a single monitor. If text appears slightly tinted on color monitors, disabling the line lock may prevent this problem.

NORTH DIRECTION

User-definable setting that may correspond to magnetic north or some well-known landmark. Used to approximate the camera dome's pointing direction when Direction Indicators are enabled.

ON-SCREEN MENU

The text overlay menu system used for setting dome features. This utility is accessed using a keystroke combination. The utility provides settings for camera functions, zoom, alarms, text display, and password protection.

PATTERN

A series of pan, tilt, zoom and focus movements from a single programmable dome. Up to 8 patterns may be programmed for the dome camera.

PRESET

Programmed video scene, based on a specific pan, tilt, zoom, and focus settings. Up to 240 presets may be programmed for the dome camera.

PRIVACY ZONES

Privacy zones are areas that are masked. These masks prevent operators of the surveillance system from viewing these designated zones. The Privacy Zones move in relation to the dome camera's pan/tilt position. In addition, the apparent size of the Privacy Zone adjusts automatically as the lens zooms in or out. Up to eight Privacy Zones may be established for a dome camera.

SHUTTER LIMIT

Setting used to define the maximum exposure time for the Open Shutter setting. The values for the setting range from 1/2 to 1/60. The default setting is 1/4.

WHITE BALANCE

Adjustments in the color hue (red and blue) gains for a camera so that true white appears white in the image. It is normally compensated for by the automatic gain control. In some lighting conditions, you may need to manually adjust the red and blue settings for optimal viewing. When Automatic White Balance is enabled, the camera measures the image and automatically adjusts the red and blue settings to balance white. When Automatic White Balance is disabled, the camera uses the values set for the red and blue settings to balance white.



CHRONO Series

8 & 16 Channel Digital Video Recorders

- Highly efficient H.264 compression
- Built-in Data Redundancy
- Real-time recording and real-time playback
- System Setup Wizard and User Friendly GUI
- Multi-Resolution recording
- 4 Spot Output (16 Channel)
- Highly efficient and stable proprietary Database Structure
- Identical GUI for DVR and client viewer
- Built-in Point-of-Sales support
- Web clients & CMS(Central Management Software) Included
- iPhone client - Coming late 3rd quarter 2010





VT-KBD1

Xpress 3-Axis Keyboard Controller for Xpress PTZs

- 3-Axis 64 Step Variable-Speed Joystick
- Auto Focus with Manual Override
- Large 1 1/2" x 5 3/16" LCD display
- Control up to 256 Devices including Xpress Domes and VITEK Saga Series Digital Video Recorders
- Digital Flip to follow objects (Enable/Disable)
- 3 X 6 Programmable function keys
- Recall 8 Pre-Programmed tours
- Recall up to 248 Preset Positions
- Built-in RS-485/422 half-duplex mode supports up to 64 devices. Simplex mode supports up to 256 devices.
- Real-time Clock

NOTES

VITEK LIMITED PRODUCT WARRANTY

VITEK products carry a three (3) year limited warranty. VITEK warrants to the purchaser that products manufactured by VITEK are free of any rightful claim of infringement or the like, and when used in the manner intended, will be free of defects in materials and workmanship for a period of three (3) years, or as otherwise stated above, from the date of purchase by the end user. This warranty is non-transferable and extends only to the original buyer or end user customer of a VITEK Authorized Reseller.

The product must have been used only for its intended purpose, and not been subjected to damage by misuse, willful or accidental damage, caused by excessive voltage or lightning.

The product must not have been tampered with in any way or the guarantee will be considered null and void.

This guarantee does not affect your statutory rights.

Contact your local VITEK Reseller should servicing become necessary.

VITEK makes no warranty or guarantee whatsoever with respect to products sold or purchased through unauthorized sales channels. Warranty support is available only if product is purchased through a VITEK Authorized Reseller.



28492 CONSTELLATION ROAD VALENCIA, CA 91355
WWW.VITEKCCTV.COM | 888-VITEK-70