

+

VITEK **VTD-IR2811DN**
INDUSTRIAL VIDEO PRODUCTS, INC. 560 TV Line Indoor Day/Night
IR Dome Camera



FEATURES:

- 1/3" Color CCD with 560 TV of Lines Resolution (600 TV Lines in B/W mode)
- 20 Infrared LEDs enable Viewing in Total Darkness up to 65 Feet
- 2.8-11mm Varifocal DC Auto Iris Lens Included
- 3-Axis Camera Bracket to help achieve the perfect viewing angle
- OSD (On Screen Display) for setup and configuration with RS-485 Support
- Advanced OSD Functions including: Digital Wide Dynamic Range (D-WDR), Digital Motion Detection, Privacy Zones, and Digital Zoom
- 12VDC/24VAC Dual Voltage Operation

VITEK



Dear Customers!

By selecting this product, you have decided to use a professional device that guarantees highest quality and reliability. We would like to thank you very much for your confidence and kindly ask you to read the following instructions carefully before Installation and operation in order to take full advantage of all quality features regarding this product.

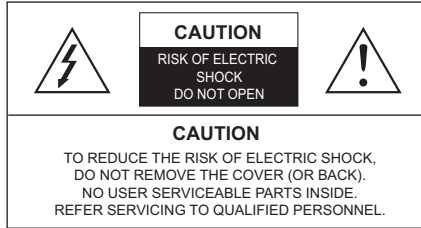

The lighting flash with an arrowhead symbol, within an equilateral triangle is intended to alert the user to the presence of non-insulated dangerous voltage within the product's enclosure that may be of sufficient magnitude to constitute a risk of electric shock to persons.



The exclamation point within an equilateral triangle is intended to alert the user to the presence of important operating and maintenance (servicing) instructions in the literature accompanying the appliance.

INFORMATION

This equipment has been tested and found to comply with limits for a Class A digital device, pursuant to part 15 of the FCC Rules. These limits are designed to provide reasonable protection against harmful interference when the equipment is operated in a commercial environment. This equipment generates, uses, and can radiate radio frequency energy and, if not installed and used in accordance with the instruction manual, may cause harmful interference to radio communications. Operation of this equipment in a residential area is likely to cause harmful interference in which case the user will be required to correct the interference at his own expense.

WARNING

Changes or modifications not expressly approved by the manufacturer could void the user's authority to operate the equipment.

CAUTION – To prevent electric shock and risk of the fire hazards

- Do NOT use power source other than that specified.
- Do NOT expose this appliance to rain or moisture.

This installation should be made by a qualified service person and should conform to all local codes.





1. Precautions -----	4
2. Limitation of liability -----	5
3. Disclaimer of warranty -----	5
4. Package -----	6
5. Special Features of the model -----	7
6. Installation -----	8~12
6-1. Opening the dome ass'y	
6-2. Vari focal Lens adjustment	
6-3. Tool-free 3-Axis mounting mechanism	
6-4. Installation overview	
7. Name and function of each part -----	13
8. Functions and operation -----	14~24
8-1. On Screen Menu (OSD)	
8-2. Setting up the menu	
8-3. LENS (Selection)	
8-4. EXPOSURE	
8-5. White Balance (WHITE BAL)	
8-6. DAY NIGHT	
8-7. 3DNR (3D Noise Reduction)	
8-8. SPECIAL	
8-9. ADJUST	
8-10. RESET	
8-11. EXIT	
9. Troubleshooting -----	25~26
10. Dimension (mm) -----	26
11. Specification -----	27



1. Precautions

- Please read the manual carefully before the installation in order to make use the camera to be set up correctly and to have the best picture quality.
- Please keep the manual in good condition for your future reference and service application.
- Installation and services should only be carried out by an authorized personnel according to local safety regulations.
- If any liquid or solid matter gets into the housing, immediately disconnect the camera from power supply and have it checked by your authorized dealer before reusing.
- Avoid installing the camera at extremely hot or cold places.
- If you are not a certified person, never try to dismantle the camera. To avoid electric shock, never remove the screws or covers. There are no parts inside that need maintenance by the user. All maintenance should be carried by qualified personnel.
- Avoid installing the camera at a place of high humidity.
- Avoid installing the camera at the place exposed to gas or oil.
- Keep the top glass of the lens always clean in order to obtain the best picture quality all the time. Be careful not to be stained by fingerprint.
- Don't face the camera directly toward sunlight or sunlight reflecting area. CCD may go defective at this condition.
- Please give a special attention to keep the unit from dangerous drop or external shock during the process of transportation or handling.
- Never try to touch the camera in wet hand. It may cause an electric shock.
- Do not expose the camera to radioactivity. It causes a serious damage on the CCD.



2. Limitation of liability

This publication is provided “AS IS” without warranty of any kind, either express or implied, including but not limited to, the implied warranties of merchantability, fitness for any particular purpose, or noninfringement of the third party’s right. This publication could include technical inaccuracies or typographical errors. Changes are added to the information herein, at any time, for the improvements of this publication and/or the corresponding product(s).

3. Disclaimer of warranty

In no event shall seller be liable to any party or any person, except for replacement or reasonable maintenance of the product, for the cases, including but not limited to below :

- (1) Any damage and loss, including without limitation, direct or indirect, special, consequential or exemplary, arising out of or relating to the product;
- (2) Personal injury or any damage caused by inappropriate use or negligent operation of the user;
- (3) unauthorized disassemble, repair or modification of the product by the user;
- (4) Inconvenience or any loss arising when images are not displayed, due to any reason or cause including any failure or problem of the product;
- (5) Any problem, consequential inconvenience, or loss or damage, arising out of the system combined by the devices of third party.
- (6) Any claim or action for damages, brought by any person or organization being photogenic subject, due to violation of privacy with the result of that surveillance camera’s picture, including saved data, for some reason, becomes public or is used for the purpose other than surveillance.



4. Package



3DNR Day/Night
IR Indoor Dome Camera 1EA

3DNR Day/Night
IR Indoor Dome Camera
INSTRUCTION MANUAL



12VDC
1200C/5VAC

Instruction manual
1EA

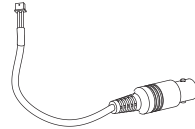

Extra Video output cable
1EA



Tapping screws
2EA



Plastic anchor
2EA

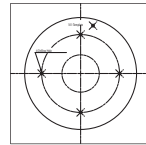

Drilling template
1EA

[Option]



Fixed Screws
2EA

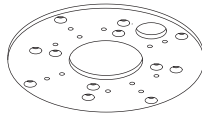

Adaptor plate
1EA



5. Special features of the model

* Ultra High Resolution

By adopting a double-speed 410,000 pixel Sony CCD, the camera produces clear picture quality with a horizontal resolution of 560 TV lines for color, and 600 TV lines for B/W.

* Digital Wide Dynamic Range (D-WDR)

By adopting a proprietary DSP chip, the camera delivers clear, high quality pictures even in backlight, by increasing exposure in dark areas while decreasing it in bright areas; a corrected image with clear details results.

* SENS-UP (0.2Lux ~ 0.0001 Lux at 128x ~ 2x Fields)

Sens-up helps maintain a bright, clear screen image by automatically detecting changes in the level of light in low light level conditions. Sensitivity can be dramatically improved up to 0.0001 Lux by adjusting the field to 128 x /max.

*3DNR

3D Noise Reduction technology used for this camera, the amount of low illumination noise has been significantly reduced, and the signal-to-noise ratio (S/N ratio) as well as horizontal resolution have been dramatically improved, resulting in a clear and sharp image display even in the dark.

* True Day & Night

The image is automatically converted from Color to B/W at the nominated lux level on the OSD.

This function maintains the picture quality as true Color at daytime and noiseless clear B/W image at nighttime enhancing the sensitivity and resolution up to 600TVL.

* Privacy Function

The privacy function enables you to select up to 8 areas and not to show & record the nominated area(s) on the screen.

* Additional functions

SYNC(INT/LL), FREEZE, V-FLIP, ROTATE, D-ZOOM, SHARPNESS, and MOTION DETECTION are provided.

* Easy to use OSD (On Screen Display) menu

A variety of beautiful functions built-in are all easily controlled by selecting text displayed on the monitor.



6. Installation

6-1. Opening the dome assembly

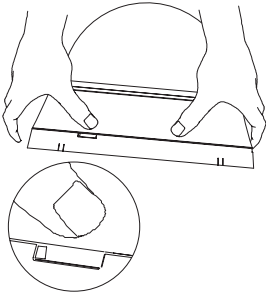

① Push the upper part of rectangular holes of the camera set by fingers and then the inner locking is separated.

OR

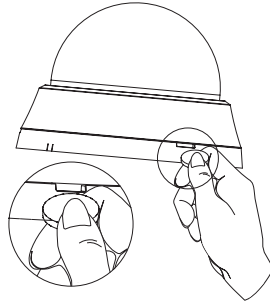

① Or Insert a coin into the rectangular holes and twist it to remove the dome assembly.

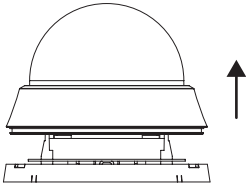

② After unlocking, separate the dome assembly from the camera set.

6-2. Varifocal Lens adjustment

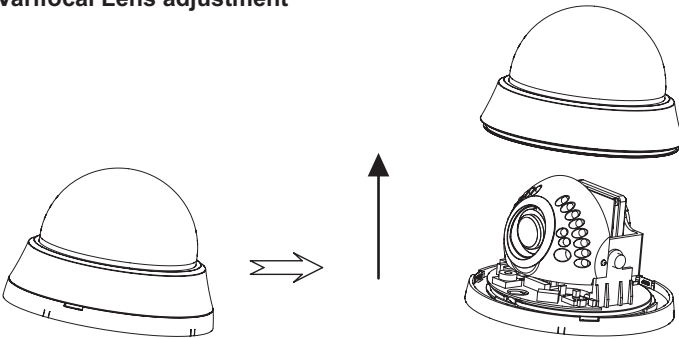



6. Installation

- ① Open dome curvature and cover as shown in 6-1.
- ② Remove the IR assembly from the bracket.
- ③ Unfasten Tilt Locking Lever by turning counterclockwise and adjust Camera Set to wanted location. And then, fasten Tilt Locking Lever tightly by turning clockwise.
- ④ Adjust focus by using Tele-Wide & Near-Far Knob.
- ⑤ Zoom (Tele-Wide)
 - Unlock the zoom lever by turning counterclockwise.
 - Move the lever to adjust the zoom.
 - Lock the lever by turning clockwise.
- ⑥ Focus (Near-Far)
 - Unlock the focus lever by turning counterclockwise.
 - Move the lever to adjust the focus.
 - Lock the lever by turning clockwise.
- ⑦ Reposition the IR assembly.

6-3. Tool-free 3-Axis mounting mechanism

Perfect 3-axis

- ? Panning axis up to 360° degree
- ? Tilting axis up to 90° degree
- ? Rotation axis up to 180° degree

a. Panning 360°

Pan Camera Set by turning post which is a camera set holder.

b. Tilting 90°

Tilt Camera Set by turning Tilt Locking Lever.

c. Rotation 180°

Rotate Camera set by grasping and turning the serration in the front of the cameraset.

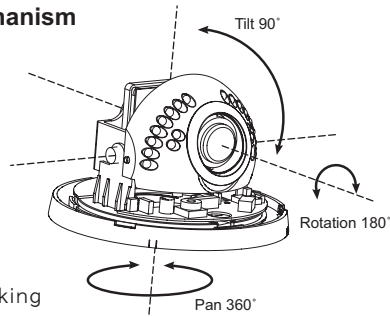

6. Installation

6-4. Installation overview

(1) Ceiling mount

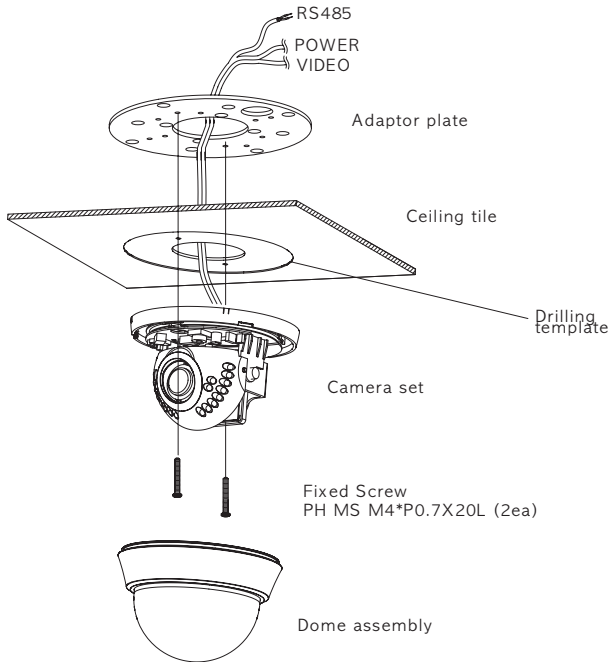

- ① Drill holes in the ceiling after doing paste a drilling template to wanted spot.
- ② Put Fixed Screws supplied in the screw holes on the Dome Base and penetrate drilling holes in the Ceiling Tile. And then, assemble them to the holes on the Adaptor Plate.
- ③ After fixing the location of the Camera Set, push the Dome Assembly(Dome Curvature and Cover) to the Dome Base.

6. Installation

(2) Wall or Slope mount

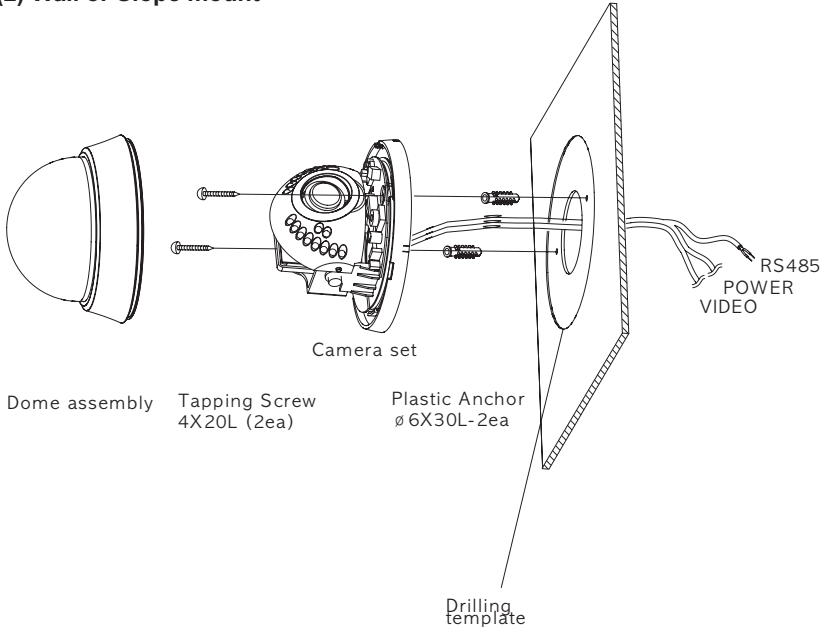

- ① Drill holes in the wall or slope after doing paste a drilling template to wanted spot.
- ② Fix Plastic Anchors in the holes.
- ③ Fix the Dome Base on the wall or slope by using Tapping Screws supplied.
- ④ After fixing the location of the Camera Set, push the Dome Assembly (Dome Curvature and Cover) to the Dome Base.

6. Installation

(3) Wall mount bracket (optional)

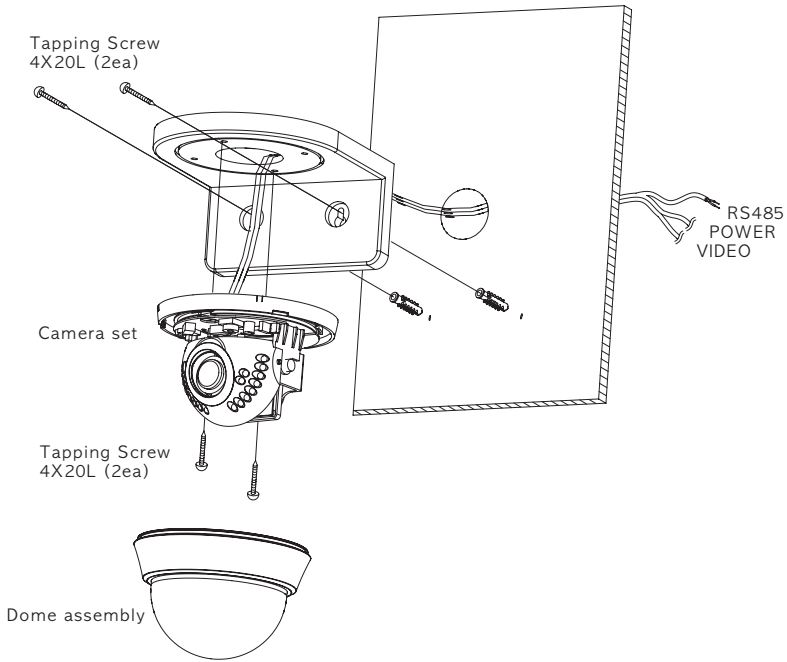

- ① Drill the holes in the wall.
- ② Insert the plastic anchor bolts into the holes.
- ③ Fix the wall mount bracket to the wall by fastening the tapping screws.
- ④ Fix the camera set with the supplied tapping screws.



7. Name and function of each part

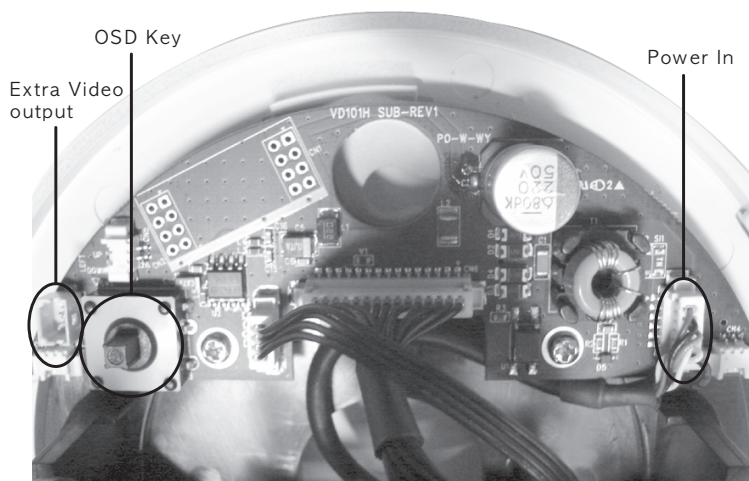

8. Functions and operation

8-1. On Screen Menu (OSD)

Setup Menu			
LENS	DC	MANUAL	
EXPOSURE	SHUTTER SENS-UP RETURN	BLC BRIGHTNESS D-WDR	AGC
WHITE BALANCE	ATW PUSH	MANUAL	AWC→SET
DAY NIGHT	COLOR	B/W	AUTO
3DNR	ON	OFF	
SPECIAL	CAMTITLE MOTION LANGUAGE	D-EFFECT PRIVACY RETURN	RS485 SYNC
ADJUST	SHARPNESS RETURN	BLUE	RED
RESET	FACTORY	RETURN	
EXIT			



8. Functions and operation

8-2. Setting up the menu

Use the function setup switch (4-direction with center-push button) on the side of the camera.

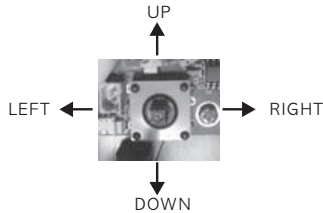

1. Press the SETUP button to access the SETUP mode.
The SETUP menu is displayed on the monitor.
2. Please select any function you wish to activate by using the UP/DOWN buttons.
The arrow can be moved up or down by using the UP/DOWN buttons. Position the arrow to point to the function you wish to operate.

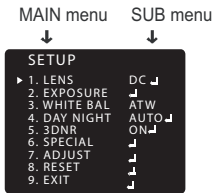

3. Change the status of the selected feature using the LEFT/RIGHT buttons.
When the LEFT or RIGHT button is pressed, available values and modes are displayed in order. Please keep pressing the button until you get to the mode you wish to operate.
4. When completed, move the arrow indicator to 'EXIT' and press the SETUP button to finish the setting.

Note

- If ◀ appears at the mode you wish to operate, it means that there is a sub-menu which can be selected by pressing the SETUP button.
- If ▶ appears at the mode item, it means that there is no mode available to be selected.



8. Functions and operation

8-3. LENS (selection)

This function is used to select the lens and to adjust the SETUP suitable to the type of lens.

- ◆ When DC lens is used.

1. Press the SETUP button.

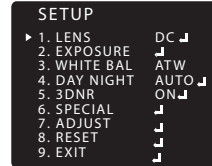

2. The LENS on the menu will automatically display <DC> in the sub-menu. If this sub-menu shows <MANUAL>, please press the sub-menu and it will be converted to <DC>.

3. DC Level volume control

Brightness level of the screen at <DC> mode is adjustable.

- Select SHUTTER menu and move the cursor to sub-menu <DC>.

- Press SETUP button and then the BRIGHTNESS CONTROL menu is on.

- Adjust the level by using the LEFT/RIGHT buttons.



4. Press the SETUP button to finish the control.

Note

At DC mode, the SHUTTER is fixed at 1/60 sec (NTSC), 1/50 sec (PAL), and the submenu at the SHUTTER mode will be in <blank>.

- ◆ When MANUAL lens is used.

1. When Manual lens is used, the menu is automatically converted to <MANUAL> mode.

2. Press the SETUP button and select <MANUAL> on the LENS mode.

3. Then the sub-menu on the SHUTTER menu is converted to <ESC> mode.

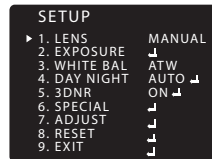

4. Brightness control
Brightness level of the screen at <ESC> mode is adjustable.

- Select the SHUTTER menu and move the cursor to sub-menu <ESC>.

- Press the SETUP button and then the BRIGHTNESS CONTROL menu is on.

- Adjust the level by using the LEFT/RIGHT buttons.



5. Press the SETUP button to finish the control.



8. Functions and operation

8-4. EXPOSURE

(1) SHUTTER (Condition and Speed control)

A. FIXED : 1/60, 1/50,,,1/100000

This mode is activated when the IRIS is set to <FIXED> mode and when Manual iris lens is used only. Following 7 steps are adjustable according to scanning system.

- NTSC : 1/60, FLK, 1/250, 1/500, 1/2000, 1/5000, 1/10000, 1/100000
- PAL : 1/50, FLK, 1/250, 1/500, 1/2000, 1/5000, 1/10000, 1/100000

* Use this function only when the light level on the application is fixed all the time.

* Factory default is NTSC 1/60, PAL 1/50

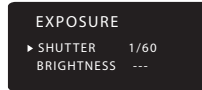

B. FLK

Please select FLK mode when flickering occurs on the screen, due to an imbalance between illumination and frequency. In most countries other than Japan do not need this set up.

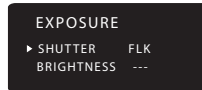

C. AUTO

The shutter speed is controlled automatically according to the brightness of the screen.



Note

Brightness is adjustable from 00~ 100. (Default : 50)

D. DSS : x2/x3/x4/x8/x16/x32/x64/x128

This is an electronically activated function to improve the sensitivity for viewing low light condition in addition to the original sensitivity from CCD sensor itself. Shutter level is adjustable from 2 to 128 times.

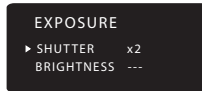

- When DSS level is higher, the much brighter picture becomes white the more ghosts are occurred.

- During DSS function in operation, Noise, Spots and White blemish are increased at the same rate of DSS level increasing. But this is not a malfunction.

(2) AGC (Auto Gain Control)

1. Please position the arrow to point to 'AGC on the SETUP menu by using the UP and DOWN buttons.

2. Please select the mode you wish to operate by pressing the LEFT and RIGHT buttons.

As the level of gain increases, the screen gets brighter and the level of noise increases.



8. Functions and operation

HIGH : The gain increases from 6dB up to 42dB
 MIDDLE : The gain increases from 6dB up to 30dB
 LOW : The gain increases from 6dB up to 18dB
 OFF : The gain is fixed at 6dB.

Note

- AGC levels can not be selected when the Day/Night mode is set to AUTO.

(3) SENS-UP

SENS UP helps maintain a bright, clear screen image by automatically detecting changes of the level of light in low illumination.

- Please position the arrow to point to 'SENS UP' on the SETUP menu by using the UP and DOWN buttons.
- Please select the mode you wish to operate by pressing the LEFT and RIGHT buttons.

AUTO : Low light level auto mode.(x8)
 OFF : The function does not operate.

Note

- When the SHUTTER is in the MANUAL mode, SENS UP does not operate.
- When the AGC is turned off, SENS UP does not operate.

(4) BLC (Backlight Compensation)

This function is useful when there is a strong backlight behind the object.

- Please position the arrow to point to 'BACKLIGHT' on the SETUP menu by using the UP and DOWN buttons.
- Please select the mode you wish to operate by pressing the LEFT and RIGHT buttons.

HIGH : The gain increases from 0 dB up to 42dB
 MIDDLE : The gain increases from 0 dB up to 30dB
 LOW : The gain increases from 0 dB up to 18dB
 OFF : BLC function does not operate.

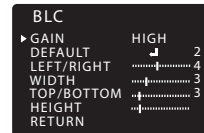
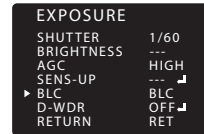
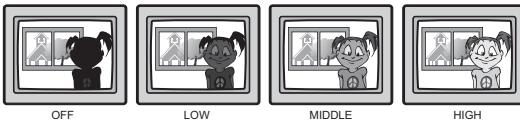



8. Functions and operation

(4-1) HSBLC (Highlight Suppression Backlight Compensation)

If there is a high light installed in a limited environment such as an apartment parking garage or gas station entrance, removing the high light makes it possible to view car license plates efficiently.

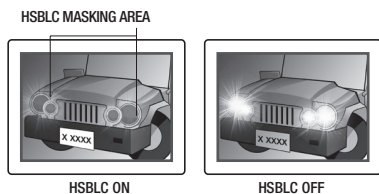

(5) D-WDR(Digital Wide Dynamic Range)

D-WDR Function scans both dark and bright areas clearly and this model realized its best set up for the most of different levels of backlit or contrast lighting situations.

- INDOOR
Select this when the level is low.
- OUTDOOR
Select this when the level is high.

Note

- D-WDR automatically turns off when the Day/Night mode is set to AUTO.
- D-WDR needs to be manually turned ON/OFF when the Day/Night mode is set COLOR or B/W.

(6) RETURN

Select this to save the change in the EXPOSURE menu and return to the SETUP menu.

8-5. White Balance (WHITE BAL)

This is useful when the cameras are installed in different artificial lighting conditions where a standard White Balance condition is not suitable for all.

1. Please position the arrow to point to 'WHITE BAL' on the SETUP menu by using the UP and DOWN selections.
2. Please select the mode you wish to operate by using the LEFT or RIGHT selection.
3. Please select one of the 5 modes below.

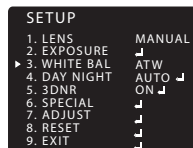
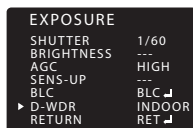
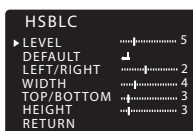
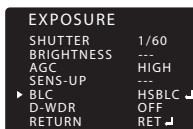

8. Functions and operation

- ATW (Auto Tracking White Balance)

This mode can be used within the color temperature range 2,000° K~ 20,000° K.

- AWC → SET (Auto White Balance control)

Please press the Tact SW while the camera is directed at a piece of white paper to obtain the optimum state under current illumination. If the environment including the light source is changed, you have to adjust the white balance again.

- MANUAL

This manual adjustment mode makes finer adjustment possible. Please select ATW or AWC first. Please change to manual adjustment mode and press the Tact SW.

Please set the appropriate color temperature, and then increase or decrease the red and blue color values while monitoring the color changes on the object.

- PUSH

It is suitable when the object's background is in high color temperature.
(Ex. Clear sky, Sunset)



8-6. DAY NIGHT

You can display pictures in Color or B/W.

1. Please position the arrow to point to 'DAY/NIGHT' on the SETUP menu by using the UP and DOWN selections.
2. Please select the mode you wish to operate by using the LEFT and RIGHT selections.

- COLOR : The picture is always displayed in color.
- BW : The picture is always displayed in black and white. Burst ON/OFF selectable.
- AUTO : The mode is switched to 'COLOR' in a normal environment, but switches to 'B/W' mode when ambient illumination is low. To set up the switching time or speed for AUTO mode, press the Tact SW.
 - DELAY : You can select the duration time about changing the Day/Night mode 0~ 63sec.
 - S-LEVEL : To adjust lux level for switching Day to Night. (Default : 65 (3Lux))
 - E-LEVEL : To adjust lux level for switching Night to Day. (Default : 60 (6Lux))

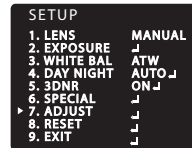

8-7. 3DNR (3D Noise Reduction)

The background noise in the low light level decreases automatically as the level of gain changes.



8. Functions and operation

1. Please position the arrow to point to '3DNR' on the SETUP menu by using the UP and DOWN selections.
2. Please select the mode you wish to operate by using the LEFT and RIGHT button.
OFF: Deactivates 3DNR, Noise is not reduced.
ON : Activates 3DNR so that noise is reduced.
3. Set the 3DNR mode to 'ON' and press the Tact SW. Then you can adjust the noise reduction level.

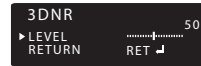
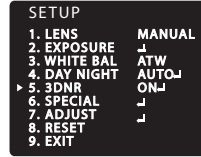

8-8. SPECIAL

1. Please position the arrow to point to 'SPECIAL' on the SETUP menu by using the UP and DOWN selections.
2. Please select the mode you wish to operate by using the LEFT or RIGHT selection.

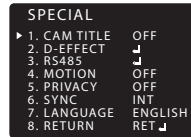

(1) CAM TITLE

If you enter a title, the title will appear on the monitor.

1. Please position the arrow to point to 'CAM TITLE' by using the UP or DOWN selection.
2. Please select 'ON' by using the LEFT and RIGHT selection. Please press the Tact SW to complete 'ON'.

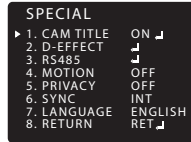

Note

- If 'OFF' is selected, the CAM TITLE does not appear on the monitor even if it has been input.

3. Up to 15 letters are offered for the CAM TITLE.
 - ① Please move the cursor to the letter to choose by using the UP and DOWN selections.
 - ② Set an ID from A, B, ~ Y, Z, 0, 1, ~ 8, 9 by using the UP, DOWN, LEFT and RIGHT selections.
 - ③ Lock in the letters by using the tact SW. When the letter is locked in, the cursor moves to the next space.
 - ④ Please repeat the above to input CAM TITLE.

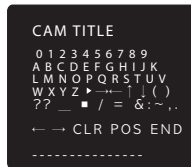

8. Functions and operation

Note

- If a wrong name has been input...
 - If you press the Tact SW after moving the cursor to CLR, all the letters will be
 - If you want to correct a letter, please move the cursor to the arrow at the bottom left of the screen and press the Tact SW.
 - Please position the cursor on the letter you wish to correct, and then move the cursor onto the letter you wish to choose and press the Tact SW.



4. When a name has been chosen, please select a position for the name to display.
 - ① Please move the cursor onto 'POS' and then press the Tact SW.
 - ② The name will appear at the top left hand corner.
 - ③ Please find the position you wish to display the name by using the 4 directional selections, and then press the Tact SW.
5. Please select 'END' and then press the Tact SW to complete CAM TITLE input.



(2) D-EFFECT

1. Please position the arrow to point to 'D-EFFECT.' on the SETUP menu by using the UP and DOWN selections.
2. Please select the mode you wish to operate by using the Tact SW.
 - FREEZE : You can view still or moving pictures.
 - V-FLIP : You can flip the picture vertically on the screen.
 - MIRROR : You can flip the picture horizontally on the screen.
 - ROTATE : You can flip the picture rotate on the screen.
 - D-ZOOM : You can use a digital zoom of x1 ~ x3.2.
 - PAN : -100 ~ 100
 - TILT : -100 ~ 100
 - GAMMA : USER / 0.05 ~ 1.00
 - NEG. IMAGE : ON / OFF
 - RETURN : Select this to save the D-EFFECT menu setting and return to the SPECIAL menu.

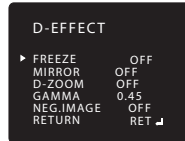



8. Functions and operation

(3) RS485

This function sets up the camera communication status when controlling the camera through an external control device.

- When the SPECIAL menu screen is displayed, press the Tact SW so that the arrow indicates 'RS485' .
- Set up the mode using the Tact SW.
 - CAM ID : Determines the camera's identification number. (between 0 and 255).
 - ID DISPLAY : Displays camera title on top left the screen.
 - BAUDRATE : You can select 2400/4800/9600/19200/38400/57600 bps.
 - RETURN : Select this to save the RS485 menu setting and return to the SPECIAL menu.

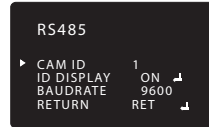

(4) MOTION

- When the SPECIAL menu screen is displayed, press the Tact SW so that the arrow indicates 'MOTION' .
- Set up the mode using the Function Setup button.
 - AREA SELECT : You can select up to 4 MD areas.
 - AREADISPLAY : Determines whether to use the MD area selected in AREA SELECT.
 - LEFT/RIGHT : Determines the coordinate of the horizontal axis.
 - WIDTH : Determines the coordinate of the horizontal size.
 - TOP/BOTTOM : Determines the coordinate of the vertical axis.
 - HEIGHT : Determines the coordinate of the vertical size.
 - SENSITIVITY : Determines the coordinate of the sensitivity
 - RETURN : Select this to save the MOTION menu setting and return to the SPECIAL menu.

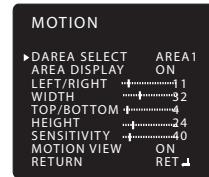

(5) PRIVACY

- When the SPECIAL menu screen is displayed, press the Tact SW so that the arrow indicates 'PRIVACY' .
- Set up the mode using the Function Setup button.
 - AREA SELECT : You can select up to 8 PRIVACY areas.
 - AREADISPLAY : Determines whether to use the selected in AREA SELECT.
 - LEFT/RIGHT : Determines the coordinate of the horizontal axis.
 - WIDTH : Determines the coordinate of the horizontal size.
 - TOP/BOTTOM : Determines the coordinate of the vertical axis.
 - HEIGHT : Determines the coordinate of the vertical size.

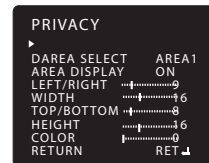

8. Functions and operation

- COLOR : You can select up to 16 PRIVACY color.
- RETURN : Select this to save the PRIVACY menu setting and return to the SPECIAL menu.

(6) SYNC

Menu is fixed to the 'INT' mode.

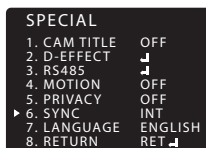

(7) LANGUAGE

You can select the menu language according to you requirements.

- ENGLISH / KOREAN / JAPANESE / CHINESE 1,2

(8) RETURN

Select this to save the SPECIAL menu settings and return to the SETUP menu.

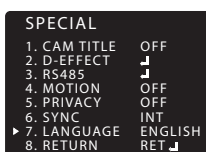

8-9. ADJUST

(1) SHARPNESS

As you increase this value, the picture outline becomes stronger and clearer. Adjust this value appropriately depending on the sharpness of the picture.

(2) BLUE

Blue color gain adjustable.

(3) RED

Red color gain adjustable.

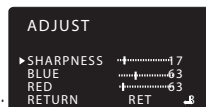

8-10. RESET

Resets the camera settings to the factory defaults.

8-11. EXIT

Press the SET button in the EXIT menu to save the current settings and exit the SETUP menu .



9. Troubleshooting

If there are problems in operating, please refer to the checklist below. If the problem persists, please contact the agent where this product is purchased.

Problems	Troubleshooting
Nothing appears on the screen.	<ul style="list-style-type: none"> ▪ Please check that the power cord and line connection between the camera and monitor are fixed properly. ▪ Please check that you have properly connected VIDEO cable to the camera VIDEO output jack.
The image on the screen is dim.	<ul style="list-style-type: none"> ▪ Is lens stained with dirt? Clean your lens with soft, clean cloth. ▪ Set the monitor to proper condition. ▪ If the camera is exposed to too strong light, change the camera position.
The image on the screen is dark.	<ul style="list-style-type: none"> ▪ Adjust the contrast feature of the monitor. ▪ If you have an intermediate device, set the 75Ω / Hi-z properly.
The camera is not working properly, and the surface of the camera is hot.	<ul style="list-style-type: none"> ▪ Please check that you have properly connected the camera to an appropriate power source.
The DAY/NIGHT menu does not work.	<ul style="list-style-type: none"> ▪ Please check that AGC of EXPOSURE SETUP menu is 'OFF' .
The SENS-UP function does not work.	<ul style="list-style-type: none"> ▪ Please check that AGC of EXPOSURE SETUP menu is 'OFF' . ▪ Please check that SHUTTER of EXPOSURE SETUP menu is 'FLK' or 'MANUAL' .
The MOTION DETECTION function is not working.	<ul style="list-style-type: none"> ▪ Please check if MOTION DETECTION function is turned on. ▪ Please check if MD LEVEL is too low. ▪ Please check the setting of the MD area.
L/L mode isn't able to be selected.	<ul style="list-style-type: none"> ▪ Please check if you connected your camera to DC power source. Connect it to AC Power source.
Color is not correct.	<ul style="list-style-type: none"> ▪ Please check the setting of WHITE BAL SETUP menu.
The screen flickers continually.	<ul style="list-style-type: none"> ▪ Please check that direction of camera turns toward the Sun.



9. Troubleshooting

Problems	Troubleshooting				
RS-485 communication fails.	<ul style="list-style-type: none"> Please check the polarity between RS-485 Control Port and RS-485 cable. 				
	485 Control Board Connection Port		RS-485 Control Port		
	(+)-CONNECTION TERMINAL (TRX+)		485+		
	(-)-CONNECTION TERMINAL (TRX-)		485-		
	<ul style="list-style-type: none"> Please check the RS-485 Communication establishment initial value. * RS-485 Communication establishment initial value 				
	Item	Camera ID	BAUD RATE	UART MODE	RET PKT
Initial value	1	9600	8-NONE-1	ENABLE	
<ul style="list-style-type: none"> We recommend that you make ground connect between camera and controller in order to maintain safety communication control. 					

10. Dimensions

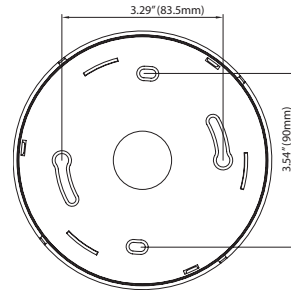
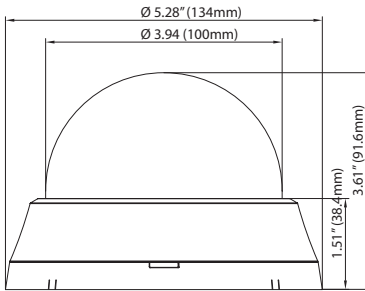

11. Specifications

VTD-IR2811DN

Image Device	1/3" Super HAD II CCD
Resolution	Color : 560 TV Lines, B/W : 600 TV Lines
Effective Pixels (Total)	768 x 494 (811x 508)
Scanning system	2:1 Interlace
Synchronization	Internal
S/N Ratio	52 dB (AGC Off, Weight ON)
Frequency	NTSC : Horizontal : 15.743KHz Vertical : 59.94Hz
Min. Illumination	0.00001 Lux (DSS), 0.2 Lux (DSS OFF) at F1.2
IR LED	20 IR LED at 850nm (40° Beam Spread)
IR Range	65 Feet (20M)
Day & Night	COLOR / Black & White / AUTO
Digital Zoom	ON / OFF (x32 max)
Varifocal Lens	2.8-11mm DC Auto Iris Varifocal Lens (Included)
IRIS Control	DC / Manual Lens
OSD Languages	English, Korean, Japanese, Chinese (1,2)
OSD Functions	Digital Wide Dynamic Range (D-WDR), Digital Motion Detection, Privacy Zones, Digital Zoom, BLC, White Balance, ESS, Sens, Gain, DNR, V-REV, H-REV, Freeze, Sharpness
Motion Detection	ON / OFF (4 Zones)
Privacy	ON / OFF (8 Zones)
Power Source	Dual Voltage: 12VDC / 24VAC
Power Consumption	DC12(450mA)/AC24(230mA)
Operation Temp.	14F~122F (-10C ~ 50C) / 30% to 80% RH
Dimension (Dia. x H)	5.28" x 3.61" (134mm x 91.6mm)
Weight	15.87 oz. (450g)

LIMITED LIABILITY WARRANTY

Your new Camera is guaranteed to be free from defects in materials and workmanship for a period of three years from the date of purchase.

The product must have been used only for its intended purpose, and not been subjected to damage by misuse, willful or accidental damage, caused by excessive voltage or lightning.

The product must not have been tampered with in any way then the guarantee will be considered null and void.

This guarantee does not affect your statutory rights.

Contact VITEK directly for all servicing.



28492 CONSTELLATION ROAD VALENCIA, CA 91355
WWW.VITEKCCTV.COM